

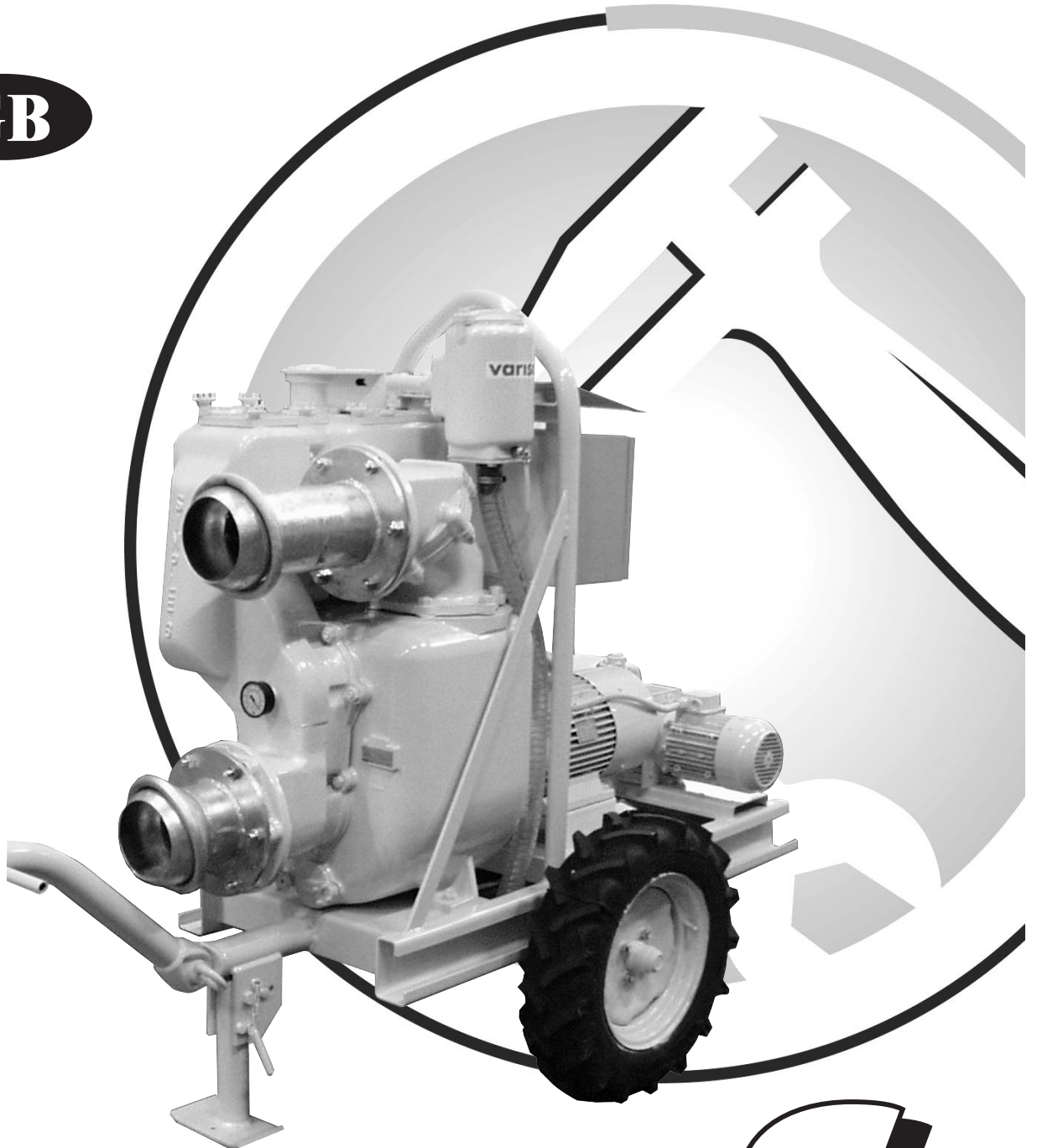

varisco®

a solid name in fluids

GB



**Instructions for the
installation, use and
maintenance of electric
high vacuum pumps**





Before starting the pump read this instruction manual carefully

The pump has been thoroughly tested for several hours before delivery and the performance has been checked and certified within acceptable limits.

If the instructions for use and maintenance are observed, the pump will give full performance for a long time. This manual also contains information for the prevention and elimination of most common operating problems.

CONTENTS

1 IDENTIFICATION	Pag. 5
1.1 Manufacturer	5
1.2 Type of pump	5
1.3 Model	5
1.4 Year of manufacture	5
1.5 Instruction book identification	5
1.6 Nameplate information	5
1.7 Field of application	5
1.8 In case of breakdown	5
2 WARRANTY	5
3 GENERAL INSTRUCTIONS	5
4 SAFETY AND ACCIDENT PREVENTION INFORMATION	6
5 IN CASE OF EMERGENCY	6
6 HANDLING AND TRANSPORT	6
6.1 Method of transport	6
6.2 Installation	6
7 STORAGE	6
8 INSTALLATION	7
8.1 Pipework	7
9 ALIGNMENT	7
10 ELECTRICAL CONNECTIONS	7
11 STARTING	8
11.1 Mechanical seal check	8
11.1.1 Pumps with type TW mechanical seals	8
11.2 Filling the pump casing	8
11.3 Priming	8
12 MAINTENANCE	8
12.1 Inspection and checks	8
12.2 Replacing the impeller	8
12.3 Replacing the wear plate	8
12.4 Replacing the mechanical seal TW	8
12.5 Positioning the impeller with reference to the wear plate	9
12.6 Replacing the check valve	9
12.7 Maintenance of the vacuum pump oil reservoir	9
12.8 Maintenance of the separation tank	10
12.9 Maintenance of the vacuum pump	10
12.10 Maintenance of the bearings	11
12.11 Replacing the bearings	11
12.12 Replacing the TWIN-DISC coupling blocks (RBD series)	11
12.13 Replacing the rubber collar of SURE-FLEX couplings	11
12.14 Replacing the rubber dowels of BALBONI GFB flexible couplings	11
13 OPERATING PROBLEMS: CAUSES AND REMEDIES	12
13.1 The pump does not prime	12
13.2 The pump does not deliver liquid	12
13.3 The pump does not have sufficient capacity	12
13.4 The pump does not provide enough pressure	12
13.5 The pump absorbs too much power	12
13.6 The pump vibrates and is noisy	12
13.7 The pump is jams	12
13.8 The mechanical seal leaks	13
13.9 The mechanical seal overheats	13
14 RESIDUAL RISKS	13
15 REPAIRS	13
16 DISASSEMBLY	13
16.1 Removing the pump from the system	13
17 ASSEMBLY	13
17.1 Mounting the pump in the system	13
18 SPARE PARTS	13
18.1 Ordering spare parts	13
19 DISPOSAL	13

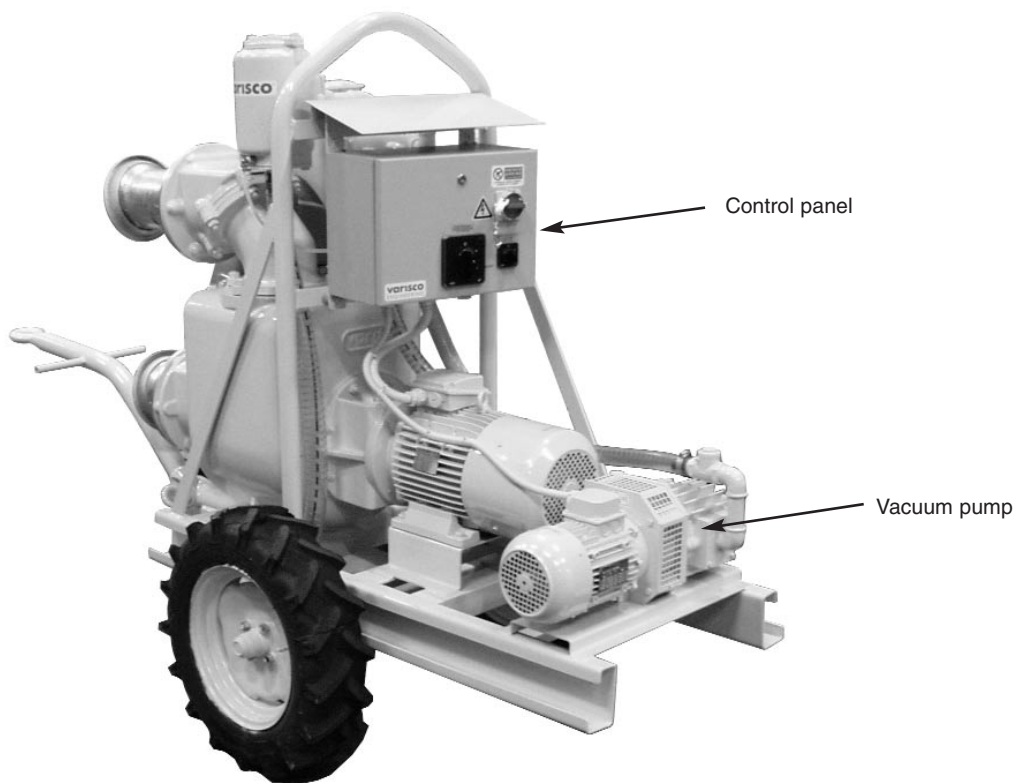
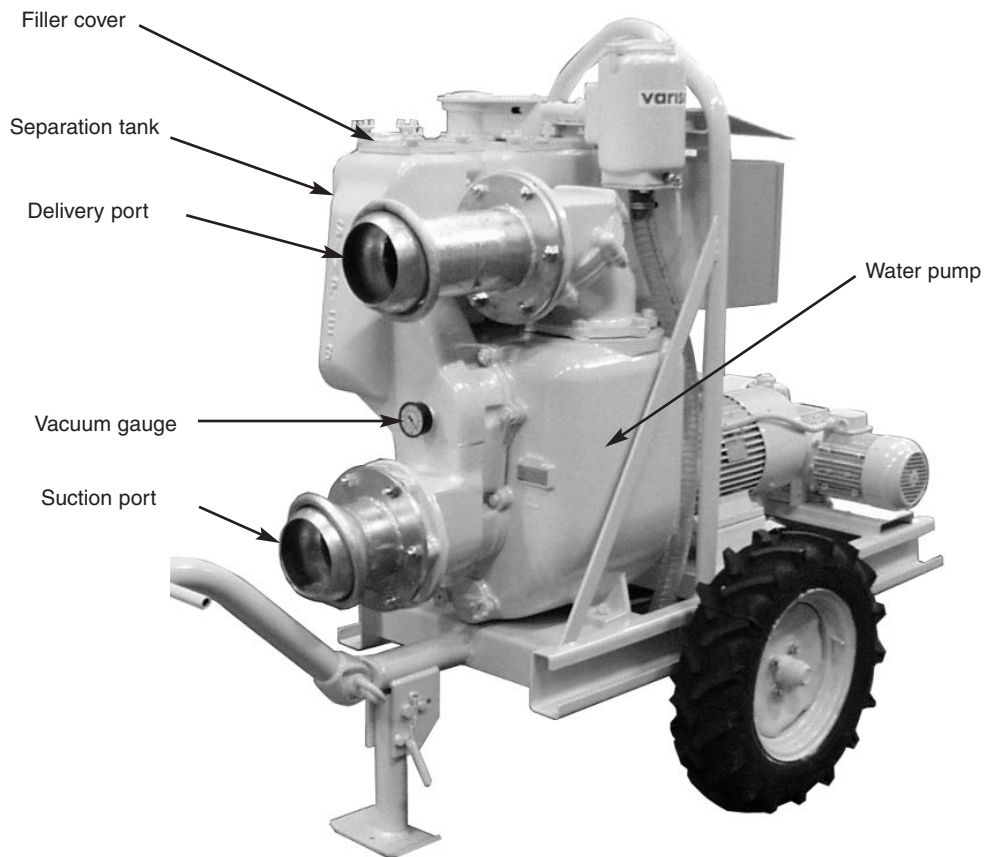

1 IDENTIFICATION

1.1 Manufacturer:

Varisco Pompe S.r.l., Zona Industriale Nord, Terza Strada 9, 35129 PADOVA, Italy

1.2 Type of pump

Horizontal self-priming centrifugal pump with open impeller for handling liquids containing solids in suspension. These pumps can operate satisfactorily with liquids containing air or dissolved gases.

1.3 Model

The type of pump is shown on the pump name plate.

1.4 Year of manufacture

The year of manufacture is indicated on the pump name plate.

1.5 Instruction book identification

Prepared: Gennaio 2002 Edition: 04 Revision: 00 Date of revision:

1.6 Nameplate information

The values shown for the capacity (m³/h), head (m), power (kW) and speed (RPM) refer to testing with water at 20° C and density 1000 kg/m³

TYPE					
	MATR.		ITEM		
	m ³ /h (max)	m (max)	kW	RPM (max)	kg

- TYPE** : identifies the model of the pump and/or unit (pump/gear box motor etc.).
- MATR.** : the serial number of the pump.
- ITEM** : the number which links the pump to the contract documents (only if requested).
- m³/h (max)** : the maximum capacity of the pump, measured at the maximum speed.
- m (max)** : the closed valve head of the pump measured at the maximum speed.
- kW** : the maximum input power of the pump at the maximum speed.
- RPM (max)** : the maximum operating rotation speed of the pump. The pump **must never** be run faster than this speed.
- kg** : the weight of the pump or of the unit excluding the weight of liquid in the pump casing.

1.7 Field of application

The pumps are suitable for handling liquids of viscosity up to 50 cSt containing solids in suspension. They are used in industry, civil engineering, shipbuilding, waste water treatment, construction and agriculture.

1.8 In case of breakdown

Contact the nearest Varisco distributor (see list below) or the Varisco factory:

Phone: + 39 049 82 94 312

Fax: + 39 049 80 76 762

2 WARRANTY

- The manufacturers guarantee that only high quality materials are used in the construction of their pumps and that machining and assembly are carried out to high standards.
- The pumps are guaranteed against defective materials or faulty workmanship for a period of one year from the date of delivery unless specifically stated otherwise in writing.
- **The warranty is not valid if the pump has been tampered with by third parties.**
- Replacement of parts or of the pump itself can only be carried out after careful examination of the pump in an authorised workshop by qualified personnel. The pump should be sent carriage paid.
- This guarantee does not cover parts subject to deterioration or normal wear and tear (seals, diaphragms, pressure and vacuum gauges, rubber or plastic items, etc.) or damage caused by misuse or improper handling of the pump by the end user.
- Parts replaced under guarantee become the property of the manufacturers.

Date

3 GENERAL INSTRUCTIONS

The goods must be examined on arrival to ascertain any damage caused during shipment. Loss or damage must be notified immediately to the carriers and to the sender. Check that the goods correspond exactly to the description on the shipping documents and report any differences as soon as possible to the sender. Always quote the pump type and serial number.

The pumps must be used only for applications for which the manufacturers have specified:

- the construction materials
- the operating conditions (pressure, speed, temperature, etc.)
- the field of application

In case of doubt, contact the manufacturers or an authorised distributor.

+ 39 049 82 94 312

4 SAFETY AND ACCIDENT PREVENTION INFORMATION

When working near the pump, dress appropriately, avoiding clothes with loose items (ties, scarves, etc.) which could get caught in moving parts. Use overalls made according to safety regulations, gloves, insulating shoes, safety glasses, ear plugs and helmet.

**Do not carry out maintenance on the engine while it is running.
Keep hands away from moving parts (e.g. belts, couplings, etc.).**

Do not mount on the pump to carry out maintenance operations of any kind.

5 IN CASE OF EMERGENCY

Turn off the electrical supply.

Notify the person responsible for running the plant immediately.

6 HANDLING AND TRANSPORT

6.1 Method of transport

The pump must be transported safely.

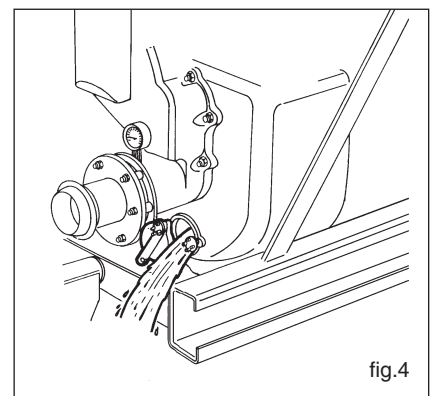
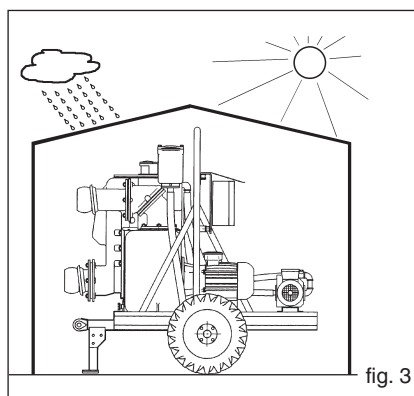
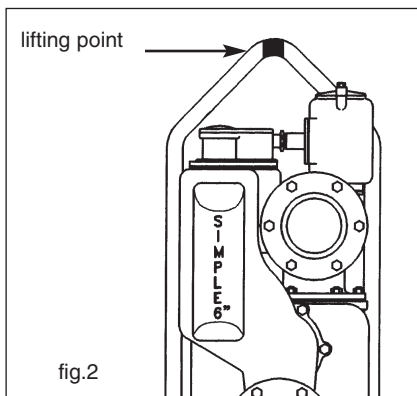
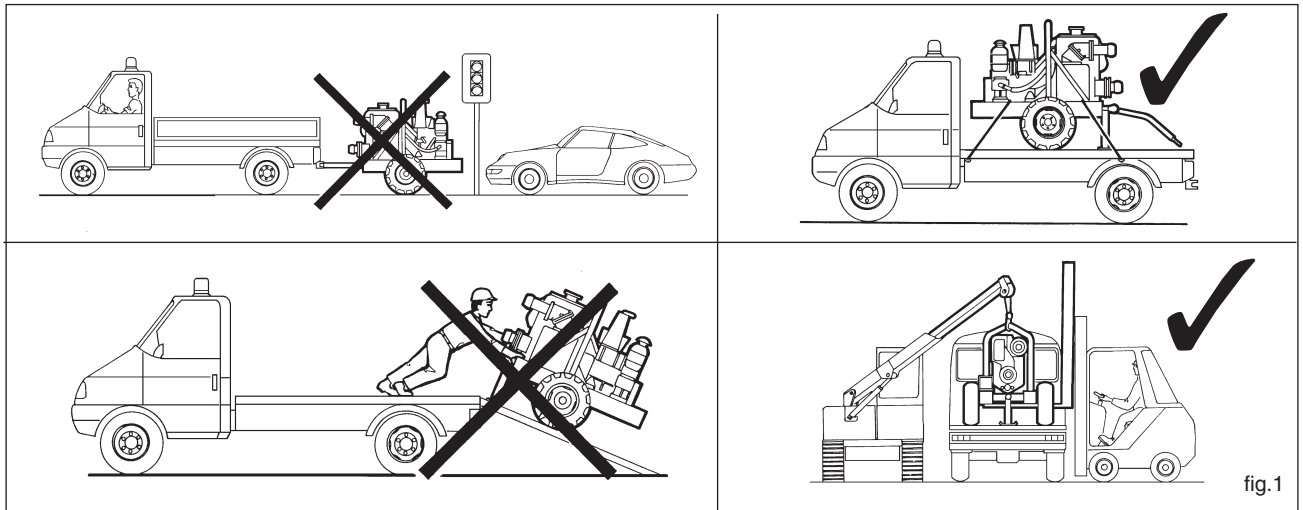

6.2 Installation

During installation and maintenance, all the components used must be handled and transported securely by using suitable slings. Handling must be carried out by specialised personnel to avoid damage to the pump and to persons. The lifting rings attached to various components should be used exclusively to lift the components for which they have been supplied. Figure 2 highlights in black the lifting points of some typical base plates.



Maximum lifting speed: $V_{max} \leq 0,5 \text{ m/s}$

Do not stand or pass under the pump while it is being hoisted!

7 STORAGE

Store the pump under cover wherever possible. If the pump must be stored in the open, cover it with a tarpaulin and grease the bearings to avoid rusting.

Avoid the accumulation of moisture around the pump.

Drain the casing through the drain cover (16) (fig. 3) and the rear plug mounted on some models. During winter months and cold weather, the liquid could freeze and damage the pump casing. If the liquid is hazardous, take all necessary precautions to avoid damage and injury before emptying the pump casing. From time to time, turn the pump shaft to avoid encrustation inside the pump (fig. 4).

8 INSTALLATION

Trailer mounted pumps must be placed in as horizontal a position as possible, as shown in figures 5

8.1 Pipework

Clean the pipes thoroughly before connecting them to the pump.

The suction line must have a diameter equal to that of the pump suction port (for diameters greater than that of the pump port, consult Varisco). If possible, avoid curves, elbows and constrictions which can limit the flow of liquid to the pump. Do not install a foot valve.

Install the pump as close as possible to the liquid to be pumped. (fig.5) Try, where possible, to reduce the length of the suction line (fig. 6).

The suction line connections must be completely airtight: check pipe threads, flange gaskets, quick couplings, etc.

The delivery line must let air escape from the system while the pump is priming.

The suction and delivery lines must be mounted in such a way as not to create a strain on the pump casing.

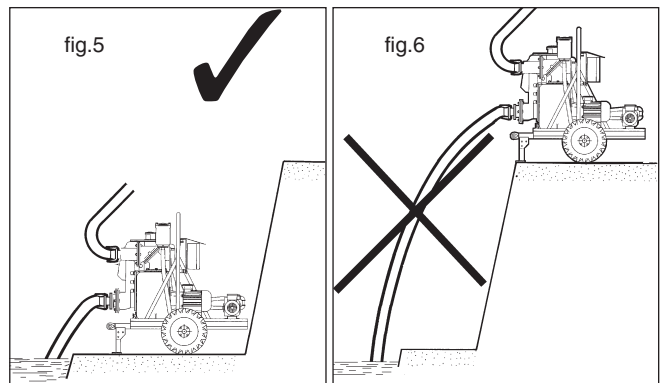

9 ALIGNMENT

Before starting the pump for the first time, it is important to check the alignment between the components of the unit (coupling/motor).

The alignment of pumps supplied on base plates is checked during manufacture. However, it should be rechecked during installation as follows:

- set up the base plate on top of the slab and insert the anchor bolts in the holds on the base plate without tightening the nuts completely
- remove the coupling guard.
- tighten the anchor bolt nuts and recheck the alignment as shown in fig.7. Adjust the alignment, if necessary, according to the type of coupling as described in paragraphs 12.12; 12.13; 12.14
- replace the coupling guard before starting the pump.

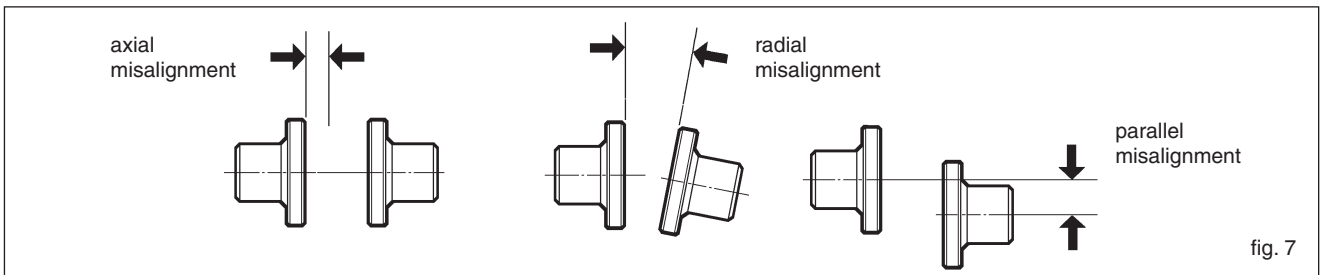

10 ELECTRICAL CONNECTIONS

Electrical connections should only be carried out by specialised personnel.

- Follow the instructions of the manufacturers of the electric motor and electrical equipment.
- **Earth the motor correctly and ensure that the electric motor is protected by an adequately rated overload cut-out.**
- Three phase electric motors are usually supplied for 380 V (star connection). For 220 V supply, connect the motor terminal box in the delta configuration as shown in the wiring diagram attached.
- Special voltage motors may be supplied. In this case, follow the instructions supplied with the motor.
- The cross section of the cables must be adequate for the current required by the motor.
- When the motor has been connected, close the delivery line gate valve and check that the direction of rotation is correct.
- The arrow on the pump casing shows the correct direction of rotation (fig.8); if the pump rotates in the opposite direction, interchange two of the three wires of the supply cable in the terminal box.

On request, pumps for brackish water can be supplied with galvanic protection against corrosion. This consists of a series of zinc discs fixed to the clean out cover. Check the state of wear of the zinc every 1000 hours and replace if necessary. While the pump is running, check that the current does not exceed that shown on the motor name plate.

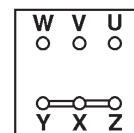
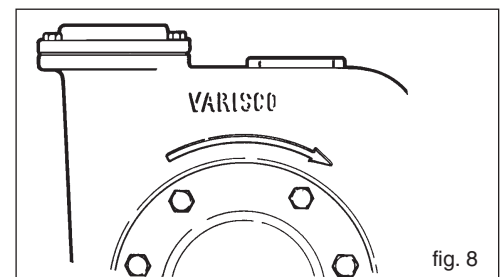

Star connection

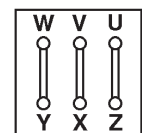

Delta connection

11 STARTING

Before operating the pump, check that the electrical and mechanical parts of the system have been correctly installed.

Check that all safety devices are operative.

Check that the pump rotates in the correct direction.

11.1 Mechanical seal check

Before starting the pump, check the type of mechanical seal shown on the pump name plate.

11.1.1 Pumps with type TW mechanical seals

Type TW mechanical seals are filled with grease during assembly. They do not require maintenance during the first 500 hours of operation of the pump. After this period, grease the seal periodically through the grease nipple fitted between the pump and the motor (fig. 9). Use NILS ATOMIC X-OT 56 grease or equivalent.

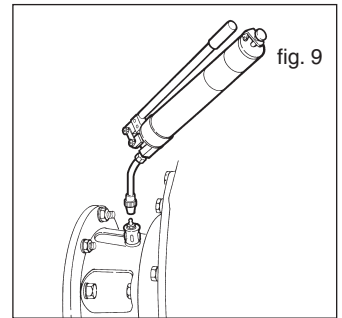

11.2 Filling the pump casing

Fill the pump casing completely with the liquid to be pumped through the opening on the top of the separation tank. When the pump is stopped, the casing does not empty and therefore it is not necessary to refill it.

11.3 Priming

Attention: if the pump does not prime, do not operate it for more than 2 minutes to avoid overheating the liquid and damaging the seal.

If the pump does not prime, read paragraph 12.7.

- Check the shaft seal for leaks.
 - Check that the current absorbed by the motor does not exceed the rated value shown on the name plate.
- If the pump does not seem to be operating normally, it must be stopped and the cause found (see paragraph 13).

12 MAINTENANCE

Before maintenance is carried out, the pump must be stopped and the electrical supply disconnected. The supply must only be switched on again by the person who carries out the maintenance.



Attention: residual liquid may be found in the pump casing, head and suction line. Take the necessary precautions if the liquid is hazardous, inflammable, corrosive, poisonous, infected, etc.

12.1 Inspection and checks

Check from time to time that the pump is working correctly. Use the instruments mounted in the system (pressure gauge, vacuum gauge, ammeter, etc.) to see if the pump continues to meet its duty.

Periodic maintenance of the parts subject to wear, in particular, the impeller and wear plate, is recommended.

12.2 Replacing the impeller (03) (fig. 10)

- Drain the pump casing as described in paragraph 7.
- Attention:** residual liquid may be found inside the pump casing, head and suction line; take all necessary precautions if the liquid is hazardous (inflammable, corrosive, poisonous, infected, etc.)
- Unscrew the nuts (52) and remove the pump casing, taking care not to damage the casing gasket (43)
 - Block the impeller and unscrew the self-locking impeller nut (33)
 - Remove the impeller and replace it with a new one
 - If necessary, replace the casing gasket (43)
 - To reassemble, proceed in reverse order
 - Check that the distance between the top of the impeller blades and the surface of the wear plate (02) is 0.5 mm (figs. 12, 13, 14)

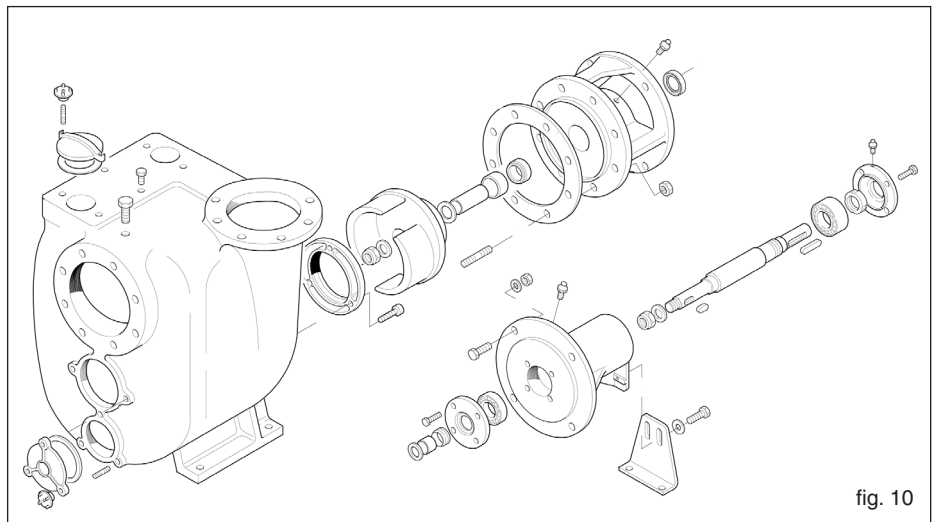

12.3 Replacing the wear plate (02) (fig. 9)

- Empty the pump casing as described in paragraph 6.
- Attention:** residual liquid may be found inside the pump casing, head and suction line; take all necessary precautions if the liquid is hazardous (inflammable, corrosive, poisonous, infected, etc.)
- Unscrew the nuts (52) and remove the pump casing, taking care not to damage the casing gasket (43)
 - Unscrew the wear plate screws (57)
 - Remove and replace the wear plate (02)
 - If necessary, replace the casing gasket (43)
 - To reassemble, proceed in reverse order
 - Check that the distance between the top of the impeller blades and the surface of the wear plate (02) is 0.5 mm (figs. 12, 13, 14)

12.4 Replacing the mechanical seal (figs. 11, 12, 13, 14, 15)

- Empty the pump casing as described in paragraph 8.
- Attention:** residual liquid may be found inside the pump casing, head and suction line; take all necessary precautions if the liquid is hazardous (inflammable, corrosive, poisonous, infected, etc.)
- Remove the casing (01) taking care not to damage the casing gasket (43)

- Block the impeller (03) and remove the self-locking impeller nut (33)
- Remove the impeller (3) and impeller key (60)
- Remove the head (19). The rotating part of the seal (40) mounted on the shaft sleeve (31) will slide off the shaft together with the head
- Remove the stationary seal (39) and its gasket (38) from the head
- Remove the lip seal (41)
- Wash the head with solvent to remove any residue of grease and clean the seats of the stationary seal and lip seal thoroughly
- Mount a new lip seal in the head. To facilitate assembly, smear a little oil on the seat and on the outer surface of the lip seal
- Mount the stationary portion of the seal (39) together with its gasket (38). To facilitate this operation, wet the seat on the head and the gasket with methylated spirits. If necessary, use a wooden plunger or similar to push the stationary seal (39) into its seat
- **Reassemble the head taking care not to touch the shaft with the stationary seal seat. If this is ceramic, it could easily break or chip**
- Tighten the head screws (45) and nuts (45.1)
- Smear the gasket of the rotating seal seat (40) and the shaft sleeve (31) with oil and slip the seal on to one end of the shaft sleeve
- Slip the sleeve and seal on to the shaft and push to overcome the slight resistance offered by the lip seal. **Take care that the seal does not slip off the shaft sleeve**
- Mount the seal support ring (25.1). Push this forward until it is possible to reassemble the impeller key (60)
- Reassemble the impeller (03), the impeller washer (66) and tighten the impeller nut (33)
- If the impeller nut is a dome nut without the nylon self-locking insert, clean the threaded extremity of the shaft carefully and lay two strips of LOCTITE 243 on two opposite sides of the thread along its entire length before screwing on the nut.
- Check that the distance between the impeller and the front wear plate as described in paragraph 12.5
- Reassemble the casing gasket after smearing both sides with grease
- Reassemble the casing and tighten the nuts, checking that the impeller is free to rotate
- Fill the seal lubrication chamber (see paragraph 11.1.1) with grease

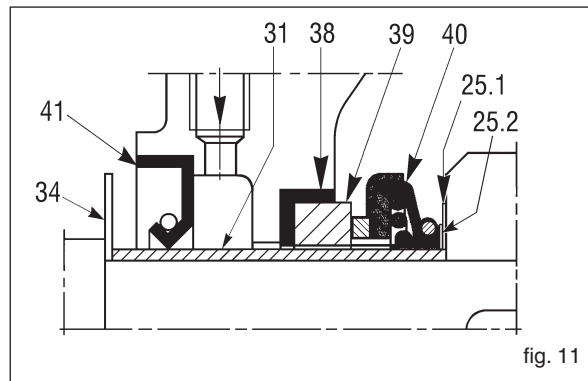
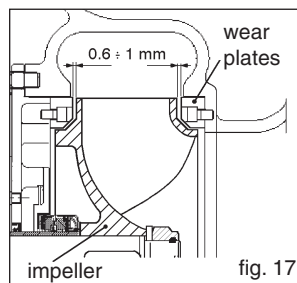
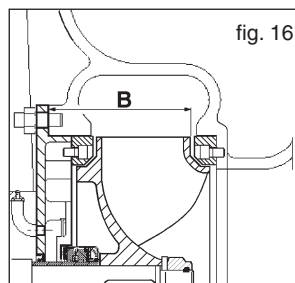
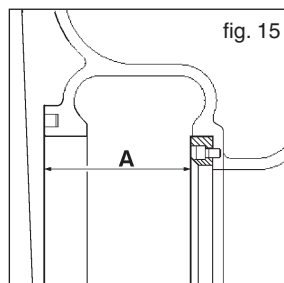
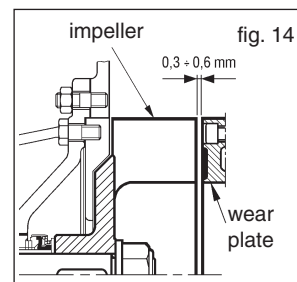
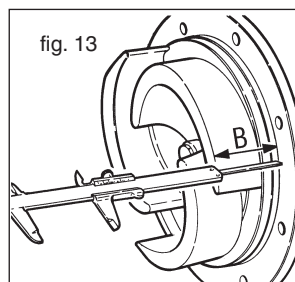
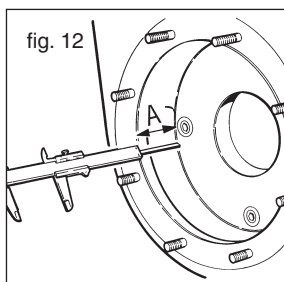

fig. 11

12.5 Positioning the impeller with reference to the wear plate(s)

- In all models, the distance between the top of the impeller blades and the surface of the wear plate must be between 0.3 - 0.6 mm (fig. 14). For the 12" model, the distance between the impeller and the front and rear wear plates must be between 0.6 - 1 mm (fig. 17).
To achieve this, dimensions A and B in figs. 12, 13, 15, 16, must be as nearly as possible equal. To this end, use the shims (25.2) (fig. 11) supplied with spare mechanical seals. These shims are used to move the impeller further forward if it is too far from the front wear plate or too near the rear wear plate. The shims should be mounted between the seal support ring (25.1) (fig. 11) and the impeller. Further adjustments can be carried out using casing gaskets (and rear wear plate gaskets on models which fit these). The presence of the casing gasket (43) (fig. 10) 0.5 mm thick then creates the correct distance (fig. 14).



12.6 Replacing the check valve (14) (fig. 18)

- Empty the pump casing as described in paragraph 5.
- Attention:** residual liquid may be found inside the pump casing, head and suction line; take all necessary precautions if the liquid is hazardous (inflammable, corrosive, poisonous, infected, etc.)
- Remove the nuts (390)
- Slip off the valve seat (391)
- Slip off the check valve (392)
- Mount the new check valve with the hinge towards the top
- Clean the valve seat (391) and reassemble it

12.7 Maintenance of the vacuum pump oil reservoir

Change the vacuum pump oil every 500 hours. Use only one of the following types of oil:

AGIP OTE 150, ESSO Teresso 150, IP Hydrus Oil 150, MOBIL D.T.E. Extra Heavy, TOTAL Azolla 150 or equivalent hydraulic oil normally used for air compressors.

If water or dirt is accidentally allowed to enter the air pump lubrication reservoir, stop the pump immediately, drain the oil and clean carefully. Only if large quantities of water have entered the air pump it is advisable to open one of the end covers of the air pump to clean the pump thoroughly and to lubricate the rotating parts and the stator.

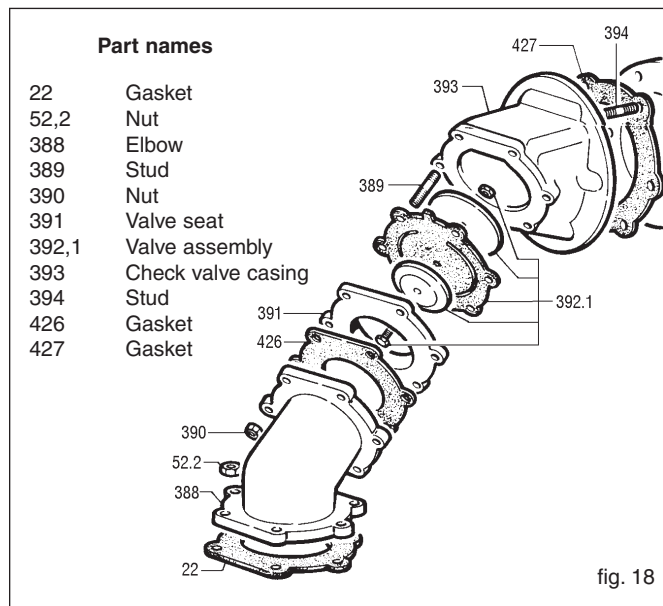

fig. 18

Every 1000 hours of operation, clean the filter inside the oil reservoir thoroughly with diesel fuel. Every time that the pump is stopped and unprimed, drain the condensate in the oil reservoir through the cock.

12.8 Maintenance of the separation tank (fig. 19, 20)

Descrizione

- 304 Cover
- 305 Plug
- 306 Stud
- 307 Screw
- 308 Screw
- 309 Screw
- 310 Upper valve housing insert
- 311 Lower valve housing insert
- 312 Cover
- 313 Valve housing
- 314 Splash guard
- 315 Gasket
- 316 Gasket
- 317 Gasket
- 318 Gasket
- 319 Gasket
- 320 Wrench
- 321 Cover
- 322 Float arm fulcrum
- 323 Splash guard
- 324 Float arm fulcrum
- 325 Float
- 326 Float rod
- 327 Bush
- 328 Ball
- 329 Valve rod
- 330 Valve rod fulcrum
- 331 Nut
- 332 Screw
- 333 Nut
- 334 Ball
- 335 Washer

All models EXCEPT 12"

fig. 19

Description

- 300 Separator housing
- 303 Gasket
- 304 Separator cover
- 306 Screw
- 307 Screw
- 308 Screw
- 309 Screw
- 310 Upper valve housing insert
- 311 Lower valvehousing insert
- 312 Cover
- 313 Valve housing
- 316 Gasket
- 318 O-ring
- 322 Float arm guide
- 325 Float
- 327 Bush
- 328 Ball
- 329 Valve rod
- 331 Nut
- 333 Nut
- 334 Ball
- 340 Manifold
- 345 Screw
- 375 Steel tube clamp
- 397 Hose

ONLY for 12" model

fig. 20

To drain the separator (in case of freezing or deposit of materials due to sedimentation) open the lower cover of the pump casing. Access can be gained to the internal levers by removing the upper cover (unscrew the bolts). When replacing float, check **dimension A** (fig. 10) it should be $455 \pm 5 \text{ mm}$ except 12". For 12" model the **dimension A** (fig. 19) it should be $448 \pm 5 \text{ mm}$

12.9 Maintenance of the vacuum pump (fig. 21)

Part names

201 Motor	206 Support turret	215.1 Bush	230 Gasket	254 Screw
201.1 Key	206.1 Screw	217 Split hub	241 Fan cover	255 Washer
202 Rotor	207 Flange	217.1 Screw	241.1 Screw	256 Coupling
202.1 Key	207.1 Screw	218 Gear wheel	241.2 Washer	257 Tube fitting
203 Stator	207.2 Screw	219 Split hub	251 Flange	258 Fitting
203.1 Pin	209 Ball bearing	220 Fan	251.1 Screw	259 Base
204 Front cover	212 Ring	221 Set of vanes	252 Flange	259.1 Screw
205 Rear cover	213 Ring	228 Gasket	252.1 Screw	259.2 Washer
205.1 Screw	214 Oil retainer	229 Gasket	252.2 Nut	260 Fan
205.2 Screw	215 Bush		253 Coupling	

fig. 21

- Check the inside of the air pump: the surface on which the vanes run must be clean and completely smooth without scores or dents (which would indicate that foreign bodies have entered the air pump).
- The rotor must also be clean and free of deposits otherwise it must be cleaned both on the surface and in the vane grooves. The vanes will be worn and therefore lower than the original height: they should be replaced when, at the point where the vane is at its maximum distance from the rotor, the part remaining in the groove is less than 18 mm. If the vanes are still in good state they should be washed and the surfaces dampened with oil used lubricating the air pump and then replaced in the grooves where they should move freely.
- Wash and dry all the other components of the pump.
- The pump can now be remounted starting from the drive end cover. The covers should be positioned on the dowel pins. Check that the gaskets are in good condition, otherwise replace them. During assembly take care not to let foreign bodies enter the pump. When the pump has been reassembled, the rotor should be free to rotate when the shaft is turned by hand.

Reconnect the lubrication tubes. Before starting up, spray a little lubricating oil inside the air pump with an oil can.

12.10 Maintenance of the bearings

The pump is supplied with the bearings already greased and does not require maintenance for the first 500 hours of operation. The bearings in the bearing housing must be lubricated appropriately, avoiding the use of too much grease which can cause overheating and, as a result, damage to the bearings.

12.11 Replacing the bearings

- Empty the pump casing
- Remove the casing, the head and the mechanical seal
- Remove the flexible coupling hub and the shaft key
- Remove the outer bearing cover (08)
- Extract the shaft from the coupling side
- Extract the bearings using a bearing extractor
- To reassemble, proceed in reverse order

12.12 Replacing the TWIN-DISC coupling blocks (RBD series)

- Remove the pump from its seat
- Remove the worn blocks and replace them with new ones
- Check the state of wear of the aluminium flange
- Couple the pump to the engine
- Maximum alignment error: 0.7 mm
- When ordering spare rubber blocks, specify the shaft diameter and the type of coupling.

Coupling type	Max. speed (RPM)	Max. torque dNm	
		Cont. duty	Intermitt. duty
8 S	4500	17	2
10 S	4000	31	30
10 SS	4000	31	30
11 S	3500	48	62
14 S	2800	94	121

12.13 Replacing the rubber collar of SURE-FLEX couplings

- Unscrew the anchor bolts at the base of the pump or motor and separate the two halves of the coupling
- Remove the worn rubber collar and replace it with a new one. In the case of two piece rubber collars (type S) leave the steel ring free to move in one of the two grooves near the indentation
- Move the pump towards the motor and fit the indentation of the half coupling to that of the rubber collar
- Close the coupling leaving an axial play of 2 mm max. for type J couplings and 3 mm max. for type S couplings
- Check the radial and angular alignment as follows:

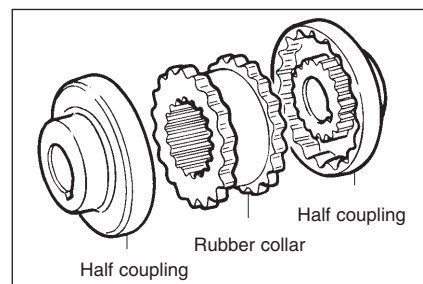

Radial: (fig. 22) with a ruler placed on the outer surface of the half couplings, measure the maximum misalignment (dimension C) in at least four points around the circumference and try to bring it as close as possible to zero (see table)

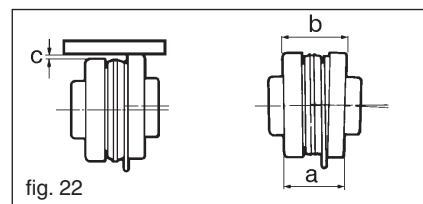

fig. 22

- **Angular:** (fig. 22) with a gauge, measure at a minimum of four points the distance between the two halves of the coupling and bring the difference (b-a) as close as possible to zero (see table)
- Tighten the anchor bolts at the base of the pump and motor
- When ordering spare parts, specify the type of coupling (stamped on the inside of the half couplings) and the shaft diameter

Coupling type	C mm	(b-a) mm	Torque N m
J4	0,25	1,1	10
J5	0,4	1,4	20
S6	0,4	1,8	40
S7	0,5	2,1	70

12.14 Replacing the rubber dowels of BALBONI GFB flexible couplings (fig. 23)

- Unscrew the anchor bolts at the base of the pump or engine and separate the two halves of the coupling
- Remove the worn dowels and replace them with new ones, fixing them in place with a little adhesive
- Move the pump towards the engine until the coupling is completely closed, then draw it back by 2-3 mm to separate the two halves of the coupling
- Tighten the bolts which anchor the pump and engine to the base plate
- When ordering dowels, specify the diameter of the shaft and the type of coupling

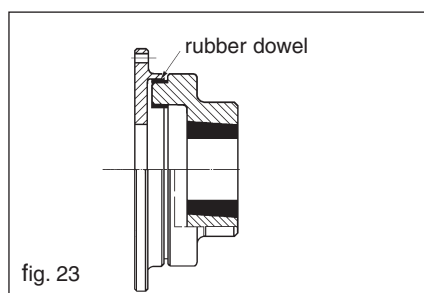

Coupling type	Max torque kgm	rpm
14	15	4800
20	25	4400
27	40	4100
40	60	3500
55	80	3300
88	110	3000
110	150	2700
145	190	2500
180	240	2200
250	300	2150
330	400	2000

13 OPERATING PROBLEMS: CAUSES AND REMEDIES

Attention: before examining the possible causes of operating problems, ensure that all control instruments (vacuum gauge, pressure gauge, revolution counter, flow recorder, electrical gauges etc.) are working correctly.

13.1 The pump does not prime

- 1 The pump casing is empty or non sufficiently full**
fill the pump casing through the opening on the top of the separation tank
- 2 The liquid inside the pump casing is overheated**
add cold liquid to the pump casing through the opening on the top of the separation tank
- 3 Air leaks in the joints or cracks in the suction line**
Check that couplings and clamps are tight and inspect the suction line
- 4 Delivery line under pressure**
bleed the delivery line
- 5 Low rotation speed of the pump**
increase the speed only after having verified the contract data and the pump performance curve
- 6 The impeller is worn or broken**
check the state of the impeller through the impeller inspection cover, or remove the pump casing as described in paragraph 12.2
- 7 The cutwater (leading edge of the volute) is worn**
remove the casing as described in paragraph 12.2. Build up the cutwater with weld and shape it to restore the original profile. If the cutwater is severely damaged, replace the casing.
- 8 The suction strainer (if fitted) is clogged**
remove the obstructions
- 9 The suction lift is too high**
reduce the suction lift
- 10 Air enters through the mechanical seal**
disassemble the seal and clean it (see paragraph 12.4); if the problem persists, change the seal
- 11 The suction or discharge lines are obstructed or clogged**
locate the obstructed or clogged area and clean

13.2 The pump does not deliver liquid

- 12 The pump is not primed**
see the points listed under 13.1
- 13 The head required by the system is greater than the rated head of the pump**
revise the system design or re-select the pump
- 14 Excessive friction losses in the suction line**
revise the distribution of elbows, valves, restrictions etc.; if necessary increase the diameter of the pipework
- 15 The impeller is clogged by foreign objects**
disassemble the casing and remove the foreign objects
- 16 The suction or discharge lines are obstructed or clogged**
locate the obstructed or clogged area and clean

13.3 The pump does not have sufficient capacity

- 17 Air leaks in the suction line**
check that the couplings are airtight and inspect the suction line
- 18 The impeller and/or wear plate are worn**
they should be replaced by disassembling the pump as described in paragraphs 12.2 and 12.3
- 19 The diameter of the suction line is too small**
replace the suction line
Check the other possible causes in paragraph 13.2

13.4 The pump does not provide enough pressure

- 20 The viscosity of the liquid is higher than expected**
contact the manufacturers after measuring the viscosity; for centrifugal pumps this should not exceed 50 cSt
Check other possible causes: see point 5 of paragraph 13.1 and paragraph 13.2

13.5 The pump absorbs too much power

- 21 The pump operates under conditions which are different for those specified**
check the operating conditions of the pump and compare them to those on the pump name plate
- 22 The density of the liquid is higher than specified**
measure the density (or specific gravity) of the liquid and compare it to the agreed figure
- 22 Incorrect alignment of the unit**
check that the unit is correctly aligned as described in paragraph 9
- 23 Friction inside the pump between the rotating and non rotating components**
remove the pump casing as described in paragraph 12.2 and check if there are signs of rubbing on the surfaces
- 24 Foreign bodies trapped in the impeller**
remove the pump casing as described in paragraph 12.2 and remove the foreign bodies

13.6 The pump vibrates and is noisy

- 25 The pump is operating at too low a capacity**
check the settings of the valves in the system and the readings on the pressure and vacuum gauges
- 26 The pump or the pipework are not well fixed**
check that the pipework is correctly clamped
- 27 The pump cavitates**
see paragraph 13.2
Check the possible causes in paragraph 13.1

13.7 The pump jams

28 Mechanical breakdown

check the shaft motor etc. for breakages

29 Foreign bodies jammed inside the pump

Remove the pump casing as described in paragraph 12.3

13.8 The mechanical seal leaks

30 TW type seal

this type of seal is suitable for pumping dirty liquids or liquids containing abrasive particles or petroleum products at temperatures up to 110°C; grease every 500 hours through the grease nipple until grease comes out behind the seal. If well lubricated, this seal can run dry for 2 minutes. If the seal leaks during operation, it must be replaced (see paragraph 12.5)

13.9 The seal overheats

The pump does not prime (see paragraphs 13.1- 13.8)

14 RESIDUAL RISKS

Residual risks are those which cannot be eliminated through the pump design:

- knocks
- anomalous pressure rises
- misuse
- manoeuvring errors in the vicinity of the pump

15 REPAIRS

Before carrying out repairs on the pump it is essential to:

- turn off the mains power (follow the directions in paragraph 10)
- close the gate valves on the suction and discharge sides of the pump
- if the pumped liquid is hot, wait until the pump has cooled down to ambient temperature
- if the pumped liquid is hazardous, follow the safety procedures for handling hazardous liquids
- drain the pump casing through the clean out cover (16) (see paragraph 6)
- remove and clean any residues of the pumped liquid

16 DISASSEMBLY

16.1 Removing the pump from the system

Carry out the instructions in paragraph 15

- remove the nuts of the suction and discharge flanges
- remove the bolts which fix the pump to the base plate
- slip the pump out of the flexible coupling (if fitted) or remove it from the electric motor
- before lifting the pump with appropriate lifting devices, check the weight of the pump

17 ASSEMBLY

17.1 Mounting the pump in the system

- lift the pump using suitable lifting devices
- position the pump on the base plate
- reconnect to the flexible coupling or electric motor
- check the alignment as described in paragraph 9
- fix the pump to the base plate
- connect the pump to the pipework
- remount any coupling guards fitted

18 SPARE PARTS

To ensure that the pump continues to operate well as time goes on, it is advisable, when ordering the pump, to acquire the spare parts recommended for the first maintenance operation:

mechanical seal
impeller
wear plate
set of gaskets
check valve
self-locking impeller nut

18.1 Ordering spare parts

To order spare parts, specify the following:

- type of pump
- serial number of the pump
- reference number and description of the part as shown in the exploded drawing

19 DISPOSAL

- Do not abandon in the environment
- Metal parts can be recycled as scrap
- Grease and oil must be recovered and stored as prescribed by the relevant legislation for disposal by approved agencies
- Elastomer gaskets must be removed and disposed of in an approved waste disposal unit.



VARISCO POMPE S.r.l.

Zona Industriale Nord - Terza Strada, 9 - 35129 PADOVA - Italy

Tel. +39 049 82 94 312 - Fax +39 049 80 76 762 - e-mail: export@variscopompe.com

Web site : www.variscopompe.com