



# varisco®

a solid name in fluids



magnetic - drive self - priming  
centrifugal pumps

# JTRM

## Why magnetic-drive pumps?

The growing demand for pumping systems that make it absolutely impossible for pumped liquids and relevant vapours to pollute the surrounding atmosphere and vice versa - resulting in chemical-physical reactions liable to alter the fluid used in the process irreparably - persuaded Varisco to come up with these new magnetic drives to be applied on the already widely popular, tried and tested internal gear rotary pumps.

### Operating principle: drive

Founded on the natural repulsion of magnets, the magnetic drive is a power transmission without any physical contact between the engine and operating unit. The magnetic cores are keyed on to the drive shaft and impeller shaft respectively.

A containment element is placed between the two cores, sealing the mechanical pumping unit. This means there is no way the liquid can escape. The system is a synchronous one, i.e. both the driving and driven shaft have exactly the same rotation speed.

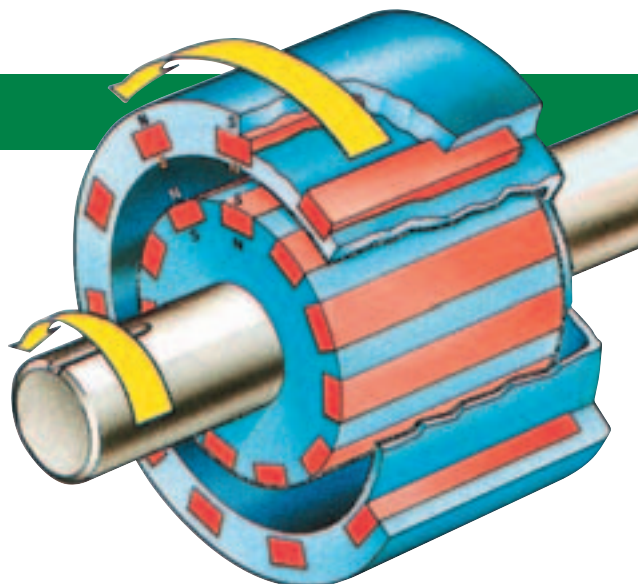

### Operating principle: J-TRM pumps

#### Self-priming principle

Air (yellow arrows) is drawn into the pump by the vacuum produced as the impeller rotates and is emulsified with the liquid (blue arrows) contained in the pump casing. The air/liquid mixture is driven into the priming chamber where the air, which is less dense, separates out and vents through the delivery line while the liquid, due to the higher density, falls back and is recirculated.

When all the air has been evacuated from the suction line, the pump primes and operates like a normal centrifugal pump. It can also handle a mixture of air and liquid. The check valve mounted in the pump suction port serves two purposes: it prevents the liquid from draining out of the suction line when the pump is not in operation, and if the suction line is drained by accident, enough liquid is retained in the pump casing for the pump to reprime. The delivery line must allow the air drawn from the suction line to vent to atmosphere.



## Advantages

- Leaks of pumped liquids totally eliminated (fully hermetic)
- Zero emissions to atmosphere
- Oversize silicon carbide bushes ensure rugged, heavy-duty construction and durability
- Elimination of costs for the replacement of mechanical seals, which are often very expensive, and production loss due to plant stoppages
- Self-priming
- Construction materials: cast iron or stainless steel as required
- Can be close-coupled to standard electric motors

## Fields of application

J-TRM pumps are mainly used for pumping liquids with abrasive solids thanks to the appropriate sizing of the cooling channel drive. Typical liquids handled include:

- acetates
- acetone
- ammonia
- caustic soda
- chlorinated solvents
- concentrated sulphuric acid
- formic acid
- fungicides
- herbicides
- lithium hydroxide
- nitric acid
- oxalic acid
- pesticides
- phenol
- polyol
- potassium nitrate
- solvents
- sulphates

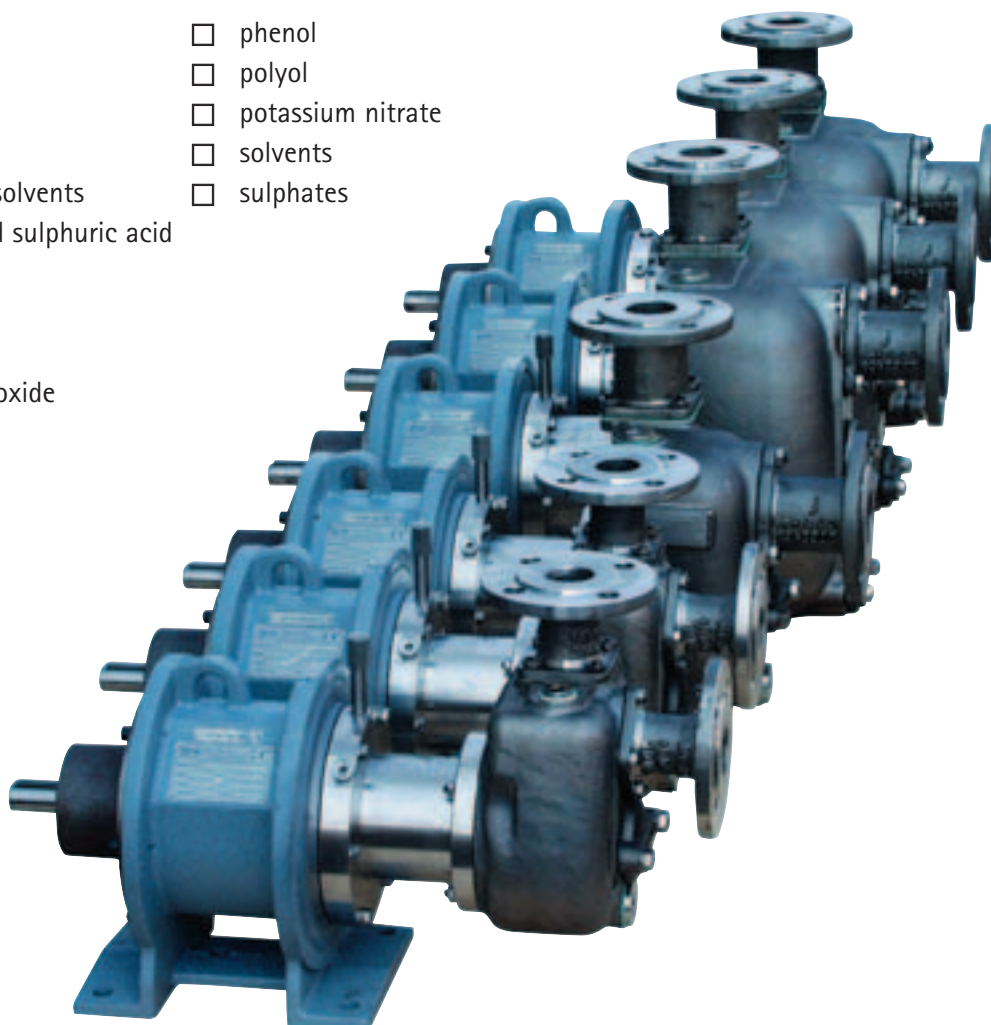

## Materials

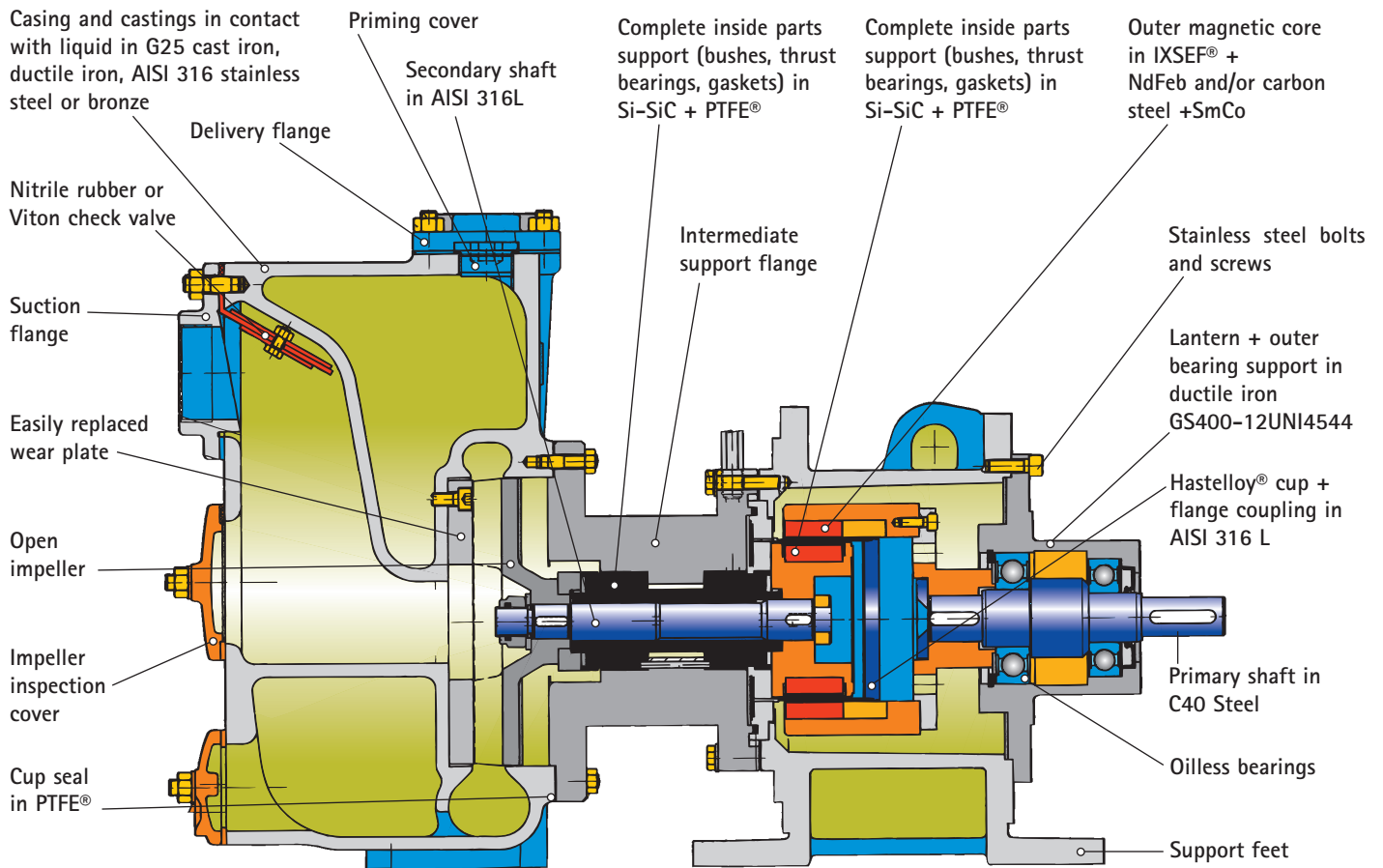

NdFeb = Neodymium - Iron - Boron  
 SmCo = Samarium - Cobalt  
 SiSiC = Silicon - Free Silica  
 PTFE = Teflon®

### Materials and configurations

Static rotating bushes in pure silicon carbide (SiC)  
 Oiled coupling lantern  
 Support flange heating jacket  
 Flange coupling for motor in B5 form  
 Magnetizing unit with external-recirculation cooling and lubrication

## Magnetic coupling variants

- +B Heating (or cooling) jacket cast around the flange supporting the inner magnetic core.
- +C Supplied ready for installation of thermal probe on flange supporting the inner magnetic core or on bush area.
- +D Heating (or cooling) jacket cast around the flange supporting the inner magnetic core + supplied ready for installation of thermal probe.

## Composition of magnetic coupling codes

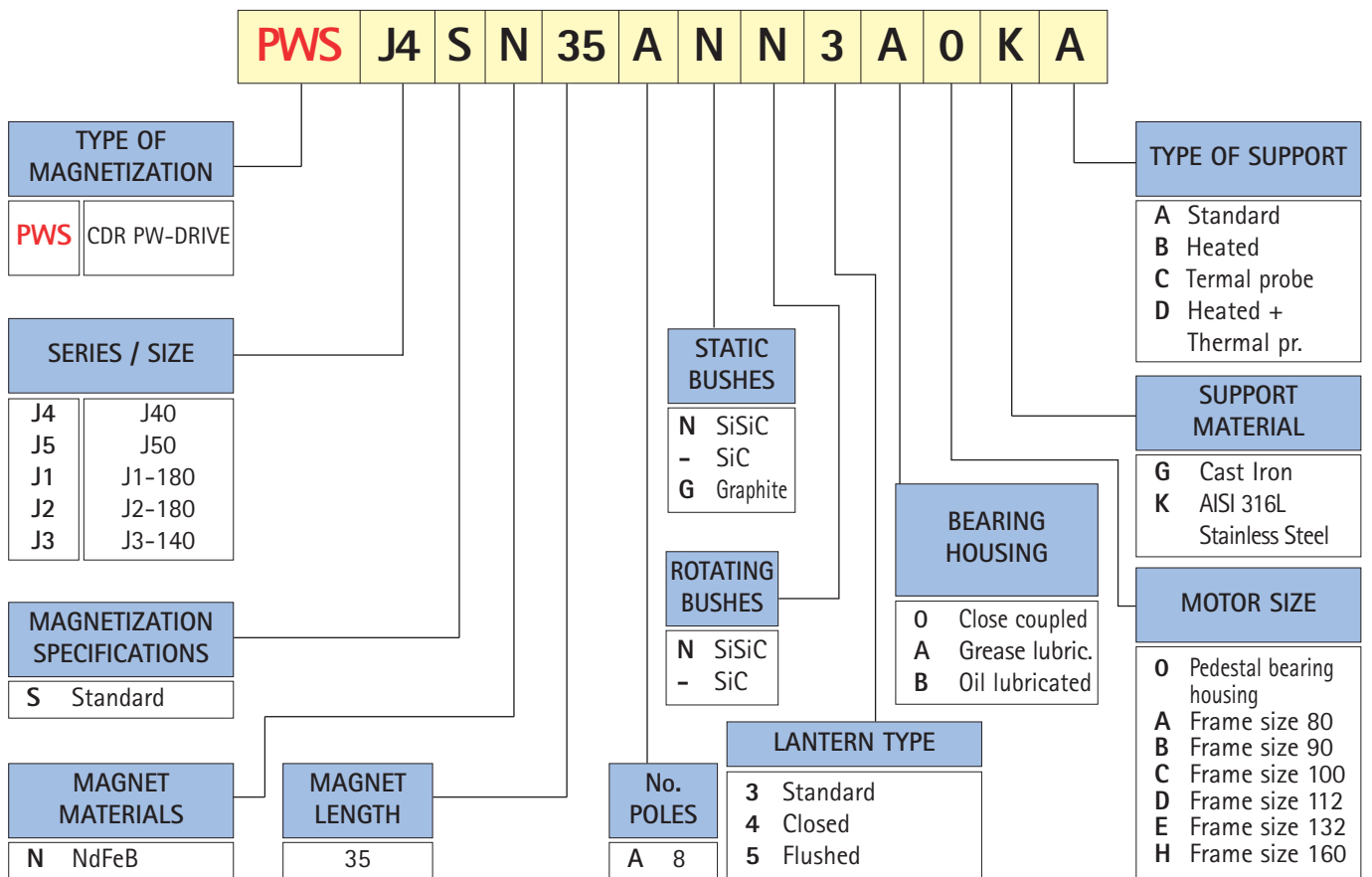

## Pump models

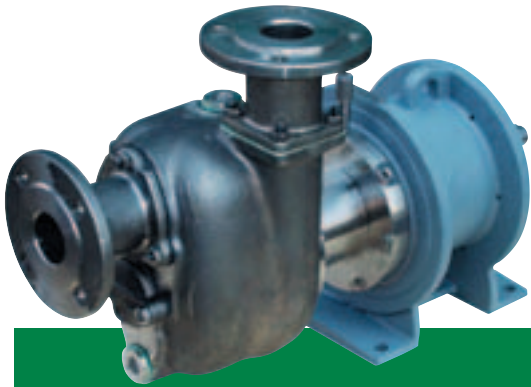

Pump size		J 40	J 50	J 1-180	J 2-180	J 3-140
Ports	Inches	1 1/2"	2"	1 1/2"	2"	3"
	mm	40	50	40	50	80
	Flanged DIN 2533 ND 16RF (on request)	DN 40	DN 50	DN 40	DN 50	DN 80

## Performance

### Input power

The input power depends on:

- The characteristics of the liquid (density, viscosity)
- The pump duty point (Capacity - Head - RPM)

For the choice of motor, consult our Sales and Engineering Departments.

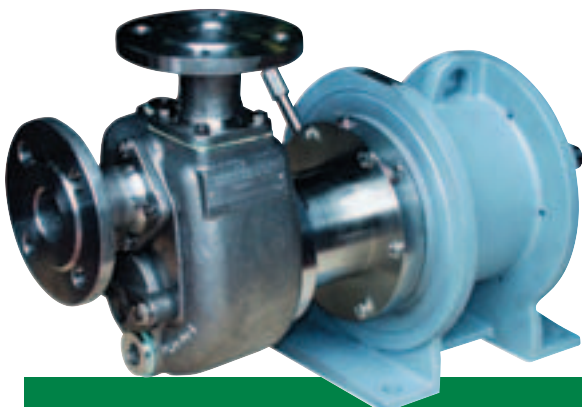
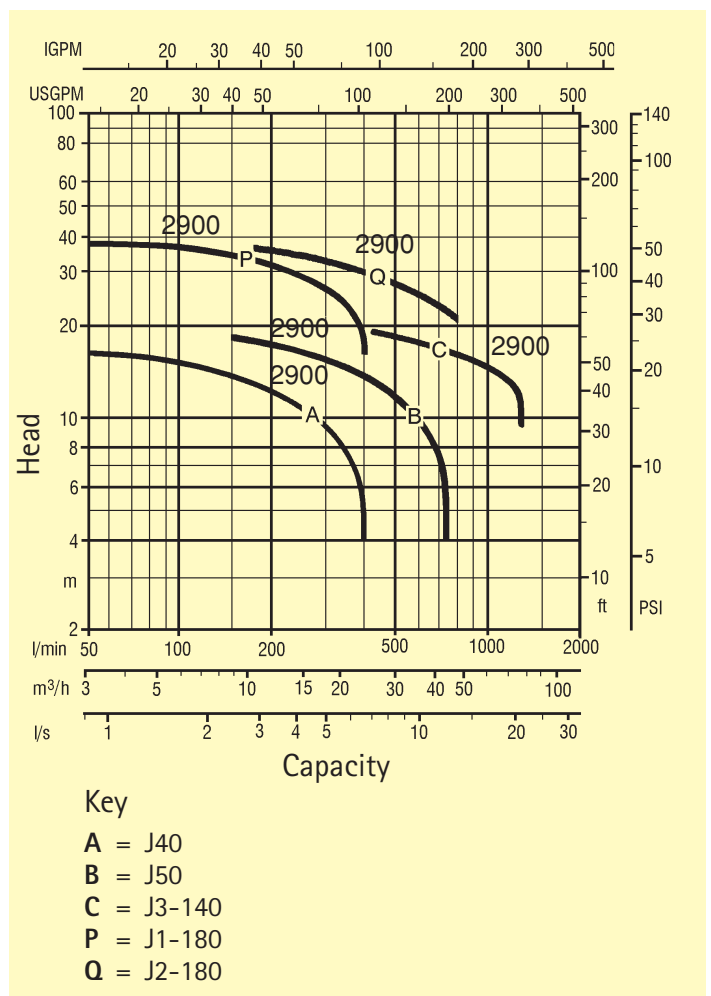

## Options

- +BI Bronze impeller
- +SSI Stainless steel impeller
- +BWP Bronze wear plate
- +SSWP Stainless steel wear plate
- +T4 Elastomers in PTFE®

# Overall dimensions

## J40 PWSJ4

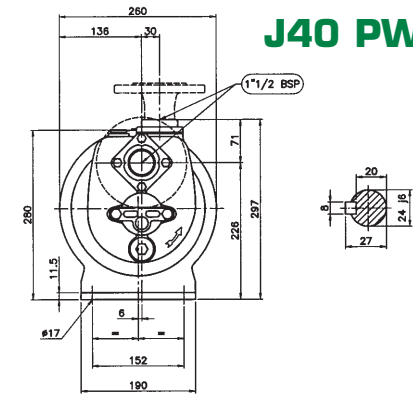

## J50 PWSJ5

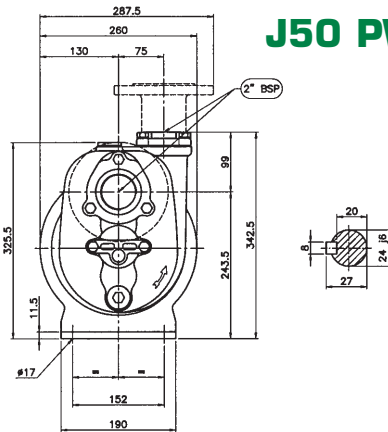

## J1-180 PWSJ1

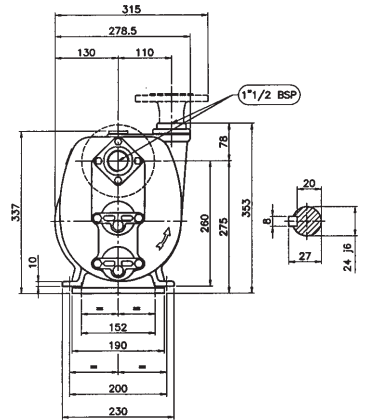
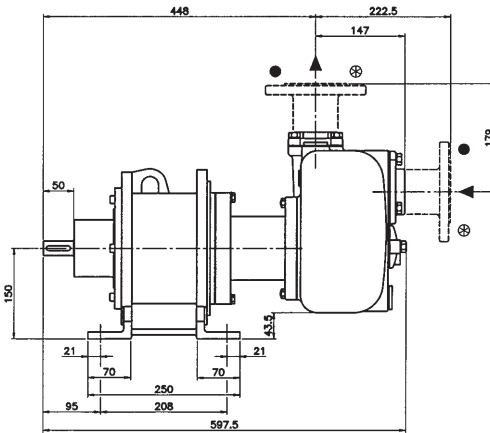
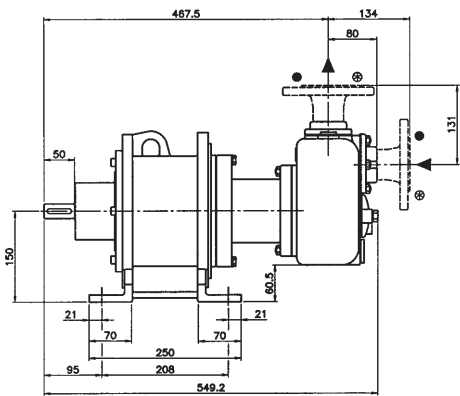

## J2-180 PWSJ2

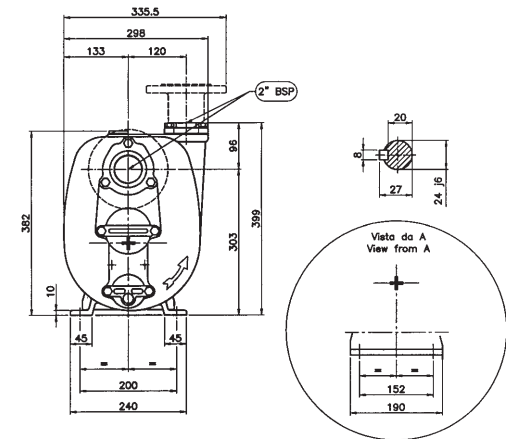

## J3-140 PWSJ3

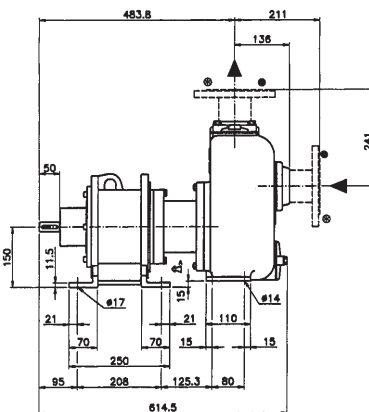
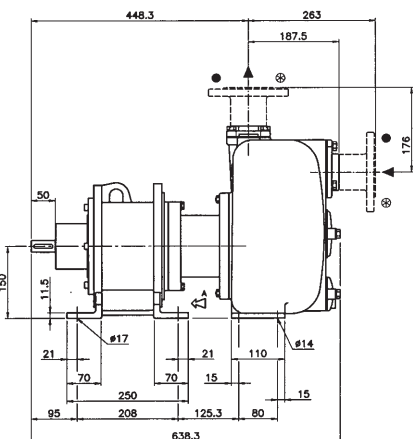
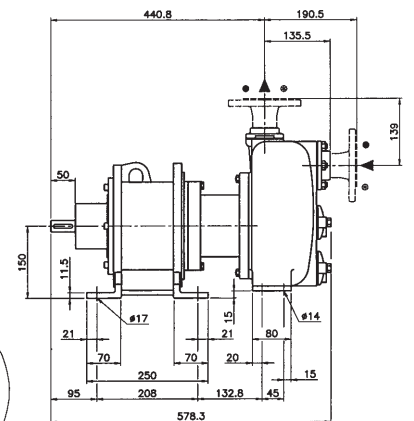
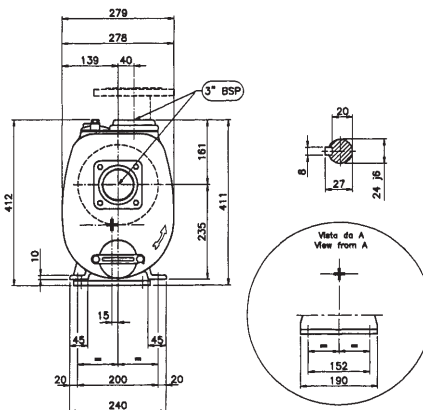

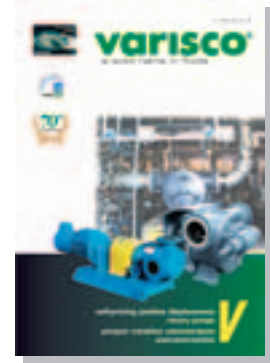
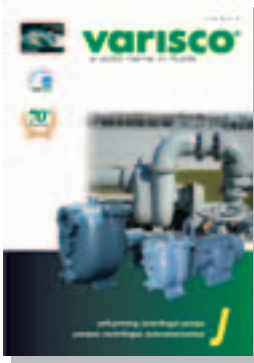

**varisco®**  
a solid name in fluids

The data and specifications mentioned herein are not binding. The manufacturer reserves the right to make changes of any nature without prior notice.

**VARISCO S.p.A.**  
Zona Industriale Nord - 35129 PADOVA - Italy  
Headquarters: Terza Strada, 9  
Factory and warehouse: Prima Strada, 37  
Tel. +39 049 82 94 111  
Fax +39 049 80 76 762  
e-mail [export@variscospa.com](mailto:export@variscospa.com)  
Web site [variscospa.com](http://variscospa.com)