

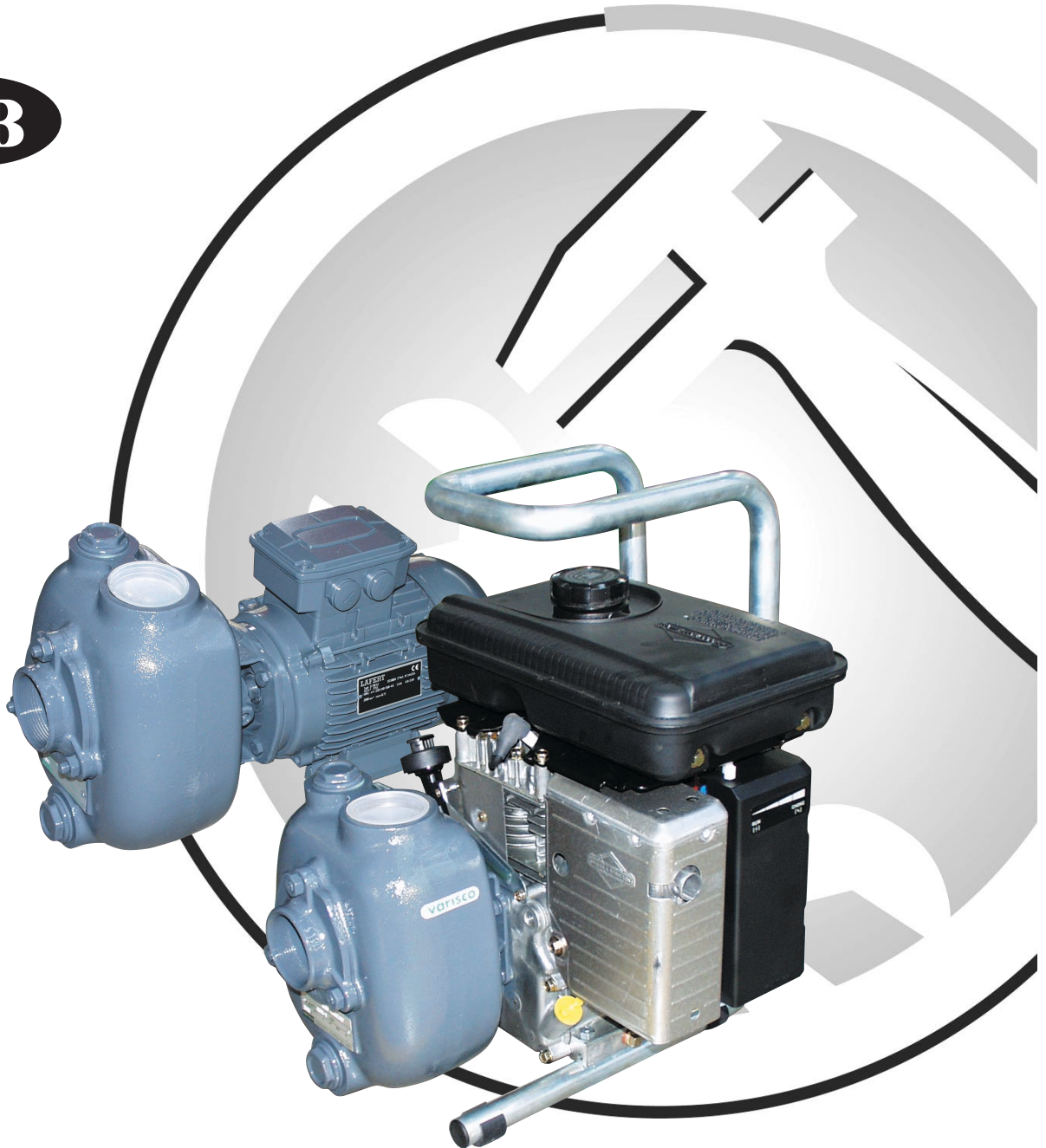

varisco®

a solid name in fluids

GB



**Instructions for the
installation, use and
maintenance of self-priming
centrifugal pumps**

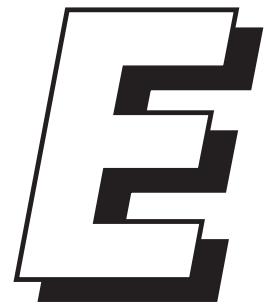

CONTENTS

| | |
|--------------------------------------------------------------------------|--------|
| 1 IDENTIFICATION | Pag. 3 |
| 1.1 Manufacturer | 3 |
| 1.2 Type of pump | 3 |
| 1.3 Model | 3 |
| 1.4 Year of manufacture | 3 |
| 1.5 Instruction book identification | 3 |
| 1.6 Nameplate information | 3 |
| 1.7 Field of application | 3 |
| 1.8 In case of breakdown | 3 |
| 2 WARRANTY | 4 |
| 3 GENERAL INSTRUCTIONS | 4 |
| 4 IN CASE OF EMERGENCY | 4 |
| 5 HANDLING AND TRANSPORT | 4 |
| 5.1 Method of transport | 4 |
| 5.2 Installation | 4 |
| 6 STORAGE | 5 |
| 7 ASSEMBLY AND COUPLING | 5 |
| 8 INSTALLATION | 5 |
| 8.1 Assembly | 5 |
| 8.2 Pipework | 6 |
| 9 ALIGNMENT | 6 |
| 10 ELECTRICAL CONNECTIONS | 6 |
| 11 STARTING | 7 |
| 11.1 Mechanical seal check | 7 |
| 11.1.1 Pumps with type TW or T4W mechanical seals | 7 |
| 11.1.2 Pumps with type T mechanical seals | 7 |
| 11.2 Filling the pump casing | 7 |
| 11.3 Priming | 7 |
| 12 MAINTENANCE | 7 |
| 12.1 Inspection and checks | 7 |
| 12.2 List of maintenance operations | 8 |
| 12.2.1 Replacing the impeller | 8 |
| 12.2.2 Replacing the check valve | 8 |
| 12.2.3 Replacing the mechanical seal | 9 |
| 12.2.4 Maintenance of bearings | 10 |
| 12.2.5 Replacing the bearings | 10 |
| 12.2.6 Replacing the TWIN-DISC coupling blocks (RBD series) | 10 |
| 12.2.7 Replacing the rubber collar of SURE-FLEX couplings | 10 |
| 12.2.8 Replacing the rubber dowels of flexible couplings | 11 |
| 13 OPERATING PROBLEMS: CAUSES AND REMEDIES | 11 |
| 13.1 The pump does not prime | 11 |
| 13.2 The pump does not deliver liquid | 11 |
| 13.3 The pump does not have sufficient capacity | 12 |
| 13.4 The pump does not provide enough pressure | 12 |
| 13.5 The pump absorbs too much power | 12 |
| 13.6 The pump vibrates and is noisy | 12 |
| 13.7 The pump is jammed | 13 |
| 13.8 The bearings have a short lifetime | 13 |
| 13.9 The mechanical seal leaks | 13 |
| 13.10 The mechanical seal overheats | 13 |
| 13.11 The elastomer portions of flexible coupling wear out quickly | 13 |
| 14 RESIDUAL RISKS | 13 |
| 15 REPAIRS | 13 |
| 16 DISASSEMBLY | 14 |
| 16.1 Removing the pump from the system | 14 |
| 17 ASSEMBLY | 14 |
| 17.1 Mounting the pump in the system | 14 |
| 18 SPARE PARTS | 14 |
| 18.1 Ordering spare parts | 14 |
| 19 DISPOSAL | 14 |

1 IDENTIFICATION

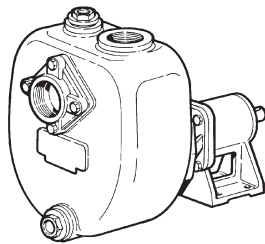

E30-160

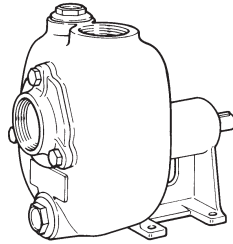

E50

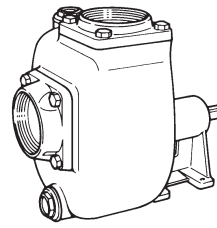

E75

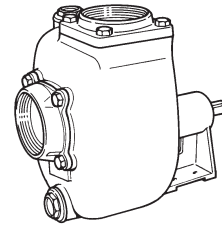

E100

1.1 Manufacturer:

Varisco Pompe S.r.l., Zona Industriale Nord, Terza Strada 9, 35129 PADOVA, Italy

1.2 Type of pump

Horizontal self-priming centrifugal pump with open impeller for handling liquids containing solids in suspension. These pumps can operate satisfactorily with liquids containing air or dissolved gases.

1.3 Model

E series.

The type of pump is shown on the pump name plate.

1.4 Year of manufacture

The year of manufacture is indicated on the pump name plate.

1.5 Instruction book identification

Prepared: January Edition: 04 Revision: 00 Date of revision:

1.6 Nameplate information

| | | | | | |
|------|-------------------------|---------|------|----------|---|
| TYPE | | | | | |
| ○ | MATR. | | ITEM | | ○ |
| | m ³ /h (max) | m (max) | kW | RPM(max) | |
| | | | | | |

The values shown for the capacity (m³/h), head (m), power (kW) and speed (RPM) refer to testing with water at 20°C and density 1000 kg/m³.

TYPE : identifies the model of the pump and/or unit (pump/gear box/motor etc.)

MATR. : the serial number of the pump

ITEM : the number which links the pump to the contract documents (only if requested)

m³/h (max) : the maximum capacity of the pump, measured at the maximum speed

m (max) : the closed valve head of the pump measured at the maximum speed

kW : the maximum input power of the pump at the maximum speed

RPM (max) : the maximum operating rotation speed of the pump. The pump **must never** be run faster than this speed.

kg : the weight of the pump or of the unit, excluding the weight of liquid in the pump casing and fuel in the fuel tank.

1.7 Field of application

The pumps are suitable for handling liquids of viscosity up to 50 cSt containing solids in suspension. They are used in industry, civil engineering, shipbuilding, waste water treatment, construction and agriculture.

1.8 In case of breakdown

Contact the nearest Varisco distributor (see list on pages 10, 11) or the Varisco factory:

Phone: + 39 049 82 94 312

Fax: + 39 049 80 76 762

2 WARRANTY

- The manufacturers guarantee that only high quality materials are used in the construction of their pumps and that machining and assembly are carried out to high standards.
- The pumps are guaranteed against defective materials or faulty workmanship for a period of one year from the date of delivery unless specifically stated otherwise in writing.
- The guarantee applies to pumps used for up to 8 hours per working day.
- Replacement of parts or of the pump itself can only be carried out after careful examination of the pump in an authorised workshop by qualified personnel. The pump should be sent carriage paid.
- **The warranty is not valid if the pump has been tampered with by third parties.**
- This guarantee does not cover parts subject to deterioration or normal wear and tear (seals, diaphragms, pressure and vacuum gauges, rubber or plastic items, etc.) or damage caused by misuse or improper handling of the pump by the end user.
- Parts replaced under guarantee become the property of the manufacturers.

3 GENERAL INSTRUCTIONS

The goods must be examined on arrival to ascertain any damage caused during shipment. Loss or damage must be notified immediately to the carriers and to the sender. Check that the goods correspond exactly to the description on the shipping documents and report any differences as soon as possible to the sender. Always quote the pump type and serial number stamped on the name plate.

The pumps must be used only for applications for which the manufacturers have specified:

- **the construction materials**
- **the operating conditions (pressure, speed, temperature, etc.)**
- **the field of application**

In case of doubt, contact the manufacturers or an authorised distributor.

4 IN CASE OF EMERGENCY

Turn off the electrical supply (for electrically driven pumps).

Shut off the engine (for engine driven pumps).

Notify the person responsible for running the plant immediately.

5 HANDLING AND TRANSPORT

5.1 Method of transport

The pump must be transported in the horizontal position.

5.2 Installation

During installation and maintenance, all the components used must be handled and transported securely by using suitable slings. Handling must be carried out by specialised personnel to avoid damage to the pump and to persons. The lifting rings attached to various components should be used exclusively to lift the components for which they have been supplied. Figure (1) highlights in black the lifting points of some typical base plates.



Maximum lifting speed: $v_{\max} \leq 0,5 \text{ m/s}$

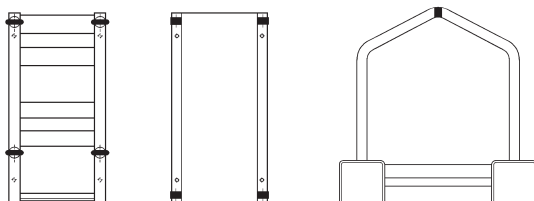

fig. 1

6 STORAGE

Store the pump under cover wherever possible. If the pump must be stored in the open, cover it with a tarpaulin and grease the bearings to avoid rusting.

Avoid the accumulation of moisture around the pump.

Never leave liquid in the pump casing. Drain the casing immediately through the drain plug (68.2) – see figures 5,6. During winter months and cold weather, the liquid could freeze and damage the pump casing. If the liquid is hazardous, take all necessary precautions to avoid damage and injury before emptying the pump casing.

From time to time, turn the pump shaft to avoid encrustation inside the pump.

7 ASSEMBLY AND COUPLING

If the pump is supplied with bare shaft (pedestal version) it must be coupled to an electric motor or internal combustion engine, taking account of the following:

- the coupling must be correctly sized for the power to be transmitted
- the coupling must be correctly aligned (see paragraph 9)
- the coupling guard must comply with applicable safety standards
- the rated power of the motor or engine
- the power absorbed by the pump (see the motor name plate)
- the motor or engine speed (see the motor name plate)
- the pump speed

8 INSTALLATION

The base plates of electrically or engine driven pumps must be anchored to a levelled concrete slab in which the foundation bolts have been buried following the diagram supplied with the unit or available on request. The slab must be robust to absorb any vibrations and sufficiently rigid to maintain the alignment of the pump to the motor or engine.

For trailer mounted pumps, block the wheels using the two chocks supplied.

8.1 Assembly

While the base plate is being anchored to the slab, check the flatness by placing a spirit level on the delivery port of the pump.

If adjustments are necessary, the face of the slab must be adapted to the base plate, **never** the base plate to the slab.

The pump casing **must** be suitably supported when the pump is coupled to a gear box for agricultural use.

8.2 Pipework

Clean the pipes thoroughly before connecting them to the pump.

The suction line must have a diameter equal to or that of the pump suction port. (For larger diameters, consult the manufacturers.) If possible, avoid curves, elbows and constrictions which can limit the flow of liquid to the pump. Do not install a foot valve: the pump has a non-return valve (14) incorporated in the suction port (fig. 5,6).

Install the pump as close as possible to the liquid to be pumped. Try, where possible, to reduce the length of the suction line.

The suction line connections must be completely airtight: check pipe threads, flange gaskets, quick couplings, etc.

The delivery line must let air escape from the system while the pump is priming.

The suction and delivery lines must be mounted in such a way as not to create a strain on the pump casing.

Engine driven pumps **must** have lengths of flexible hose to isolate the pipework from the vibrations generated by the internal combustion engine.

9 ALIGNMENT

Before starting the pump for the first time, it is important to check the alignment between the components of the unit (coupling/ motor).

The alignment of pumps supplied on base plates is checked during manufacture. However, it should be rechecked during installation as follows:

- set up the base plate on top of the slab and insert the anchor bolts in the holds on the base plate without tightening the nuts completely
- remove the coupling guard
- tighten the anchor bolt nuts and recheck the alignment as shown in fig.2. - - adjust the alignment, if necessary, according to the type of coupling as described in paragraphs 12.2.6; 12.2.7; 12.2.8.
- replace the coupling guard before starting the pump

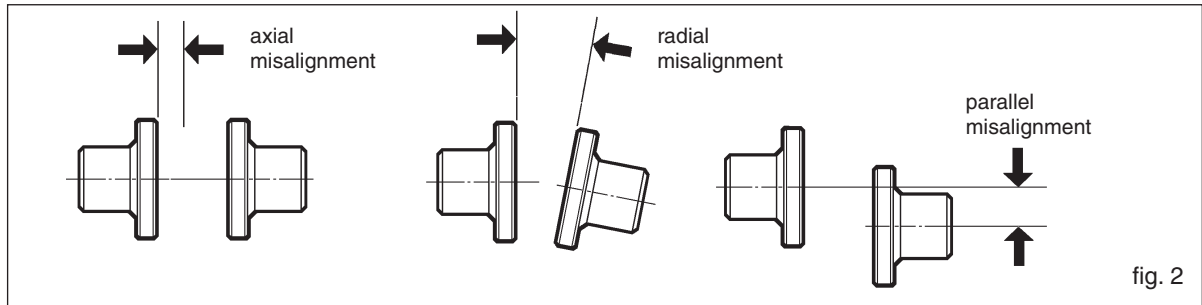

10 ELECTRICAL CONNECTIONS

Electrical connections should only be carried out by specialised personnel.

- Follow the instructions of the manufacturers of the electric motor and electrical equipment.
- **Earth the motor correctly and ensure that the electric motor is protected by an adequately rated overload cut-out.**
- Three phase electric motors are usually supplied for 380 V (star connection). For 220 V supply, connect the motor terminal box in the delta configuration as shown in the wiring diagram attached.
- Special voltage motors may be supplied. In this case, follow the instructions supplied with the motor.
- When the motor has been connected, close the delivery line gate valve and check that the direction of rotation is correct.
- The arrow on the pump casing shows the correct direction of rotation (fig.3); if the pump rotates in the opposite direction, interchange two of the three wires of the supply cable in the terminal box.
- While the pump is running, check that the current does not exceed that shown on the motor name plate.

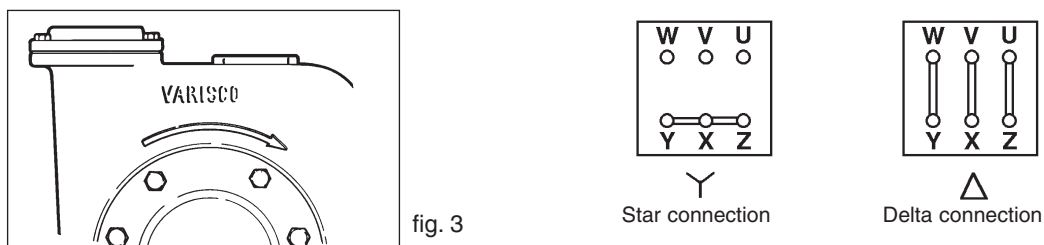

11 STARTING

Before operating the pump, check that the electrical and mechanical parts of the system have been correctly installed.

Check that all safety devices are operative.

Check that the pump rotates in the correct direction (see paragraph 10).

11.1 Mechanical seal check

Before starting the pump, check the type of mechanical seal shown on the pump name plate.

11.1.1 Pumps with type TW or T4W mechanical seals

Type TW and T4W mechanical seals are filled with grease during assembly. They do not require maintenance during the first 500 hours of operation of the pump.

11.1.2 Pumps with type T mechanical seals

Type T mechanical seals are oil lubricated. Check the oil level in the oiler; if it is low, top up with engine lubricating oil.

11.2 Filling the pump casing

Fill the pump casing completely with the liquid to be pumped through the opening on the top of the casing (fig.4). When the pump is stopped, the casing does not empty and therefore it is not necessary to refill it.

11.3 Priming

Attention: if the pump does not prime, do not operate it for more than 2 minutes to avoid overheating the liquid and damaging the seal.

If the pump does not prime, read paragraph 13.1.1.

Engine driven pumps should be brought up gradually to running speed. **Never** change the accelerator limit stop: at speeds higher than that for which the engine is set, the pump would absorb more power than the engine can supply.

Never exceed the maximum speed shown on the pump name plate.

When the pump has primed:

Check the shaft seal for leaks.

Check that the current absorbed by the motor does not exceed the rated value shown on the name plate.

If the pump does not seem to be operating normally, it must be stopped and the cause found (see paragraph 13).

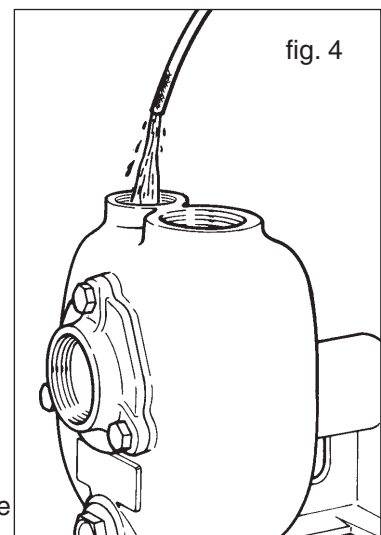

12 MAINTENANCE

Before maintenance is carried out, the pump must be stopped and the electrical supply disconnected. The supply must only be switched on again by the person who carries out the maintenance.

Attention: residual liquid may be found in the pump casing, head and suction line. Take the necessary precautions if the liquid is hazardous, inflammable, corrosive, poisonous, infected, etc.

12.1 Inspection and checks

Check from time to time that the pump is working correctly. Use the instruments mounted in the system (pressure gauge, vacuum gauge, ammeter, etc.) to see if the pump continues to meet its duty. Periodic maintenance of the parts subject to wear, in particular, the impeller and wear plate, is recommended.

12.2 List of maintenance operations

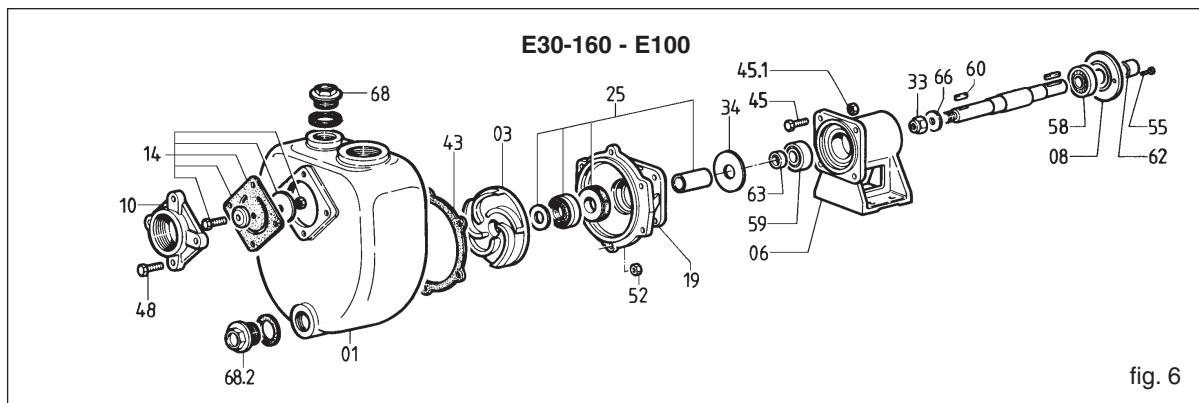
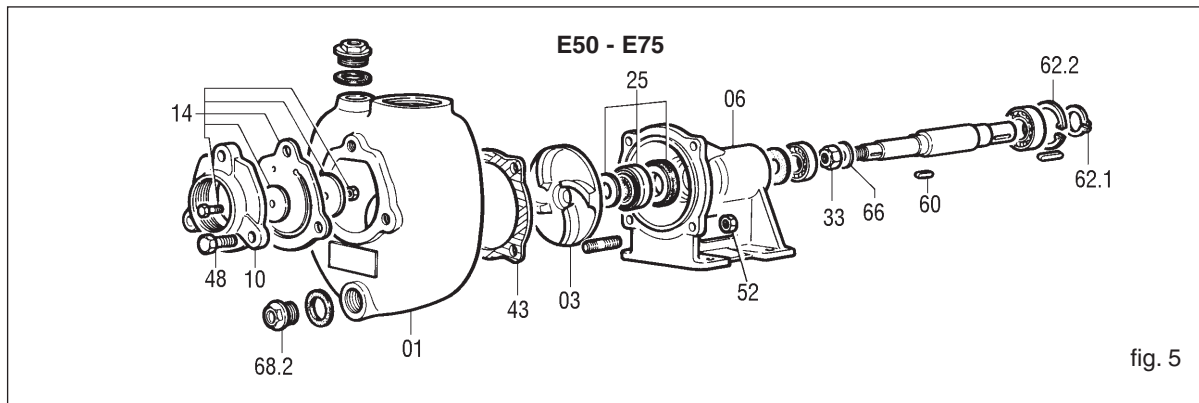

12.2.1 Replacing the impeller (03) (figs. 5, 6)

- Empty the pump casing through the drain plug (68.2)
- Unscrew the nuts (52) and remove the pump casing, taking care not to damage the casing gasket (43)
- Block the impeller and unscrew the self-locking impeller nut (33)
- Remove the impeller and replace it with a new one
- If necessary, replace the casing gasket (43)
- To reassemble, proceed in reverse order
- Check that the distance between the top of the impeller blades and the flat machined surface in the casing (01) is 0.3 – 0.6 mm (A-B in figs. 9, 10, 11)

12.2.2 Replacing the check valve (14) (figs. 5, 6)

- Drain the casing through the drain plug (68.2)
- Remove the screws (48)
- Slip off the suction flange (10)
- Slip off the check valve (14)
- Mount the new check valve with the hinge towards the top
- Clean the valve seat of the suction flange (10) and reassemble it
- Some check valves have a tongue which protrudes outside the suction flange. In this case, the weight of the check valve must be borne while tightening the nuts by pulling this tongue

12.2.3 Replacing the mechanical seal (figs. 5, 6, 7, 8)

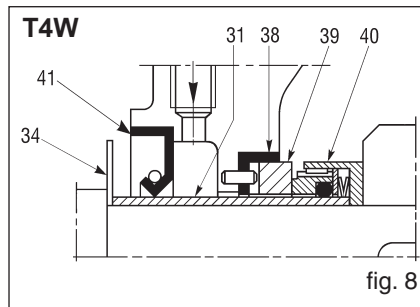
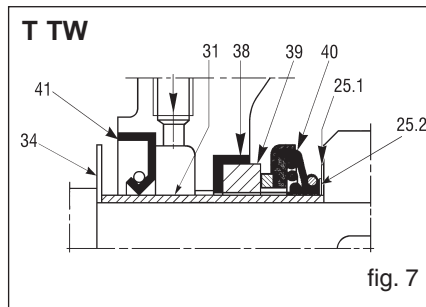

- Drain the casing through the drain plug (68.2)
- Unscrew the nuts (52) and remove the casing (01) taking care not to damage the casing gasket (43)
- Block the impeller (03) and remove the self-locking impeller nut (33)
- Remove the impeller
- Remove the head (19). The rotating part of the seal (40) mounted on the shaft sleeve (31) will slide off the shaft together with the head
- Remove the stationary seat (39) and its gasket (38) from the head

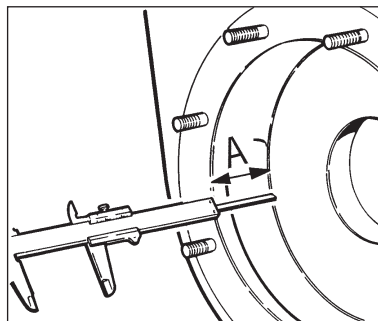

fig. 9

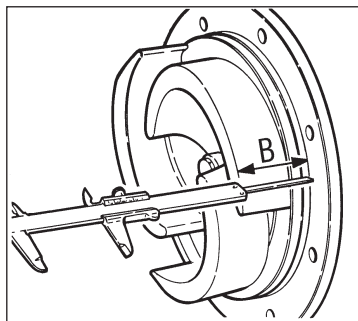

fig. 10

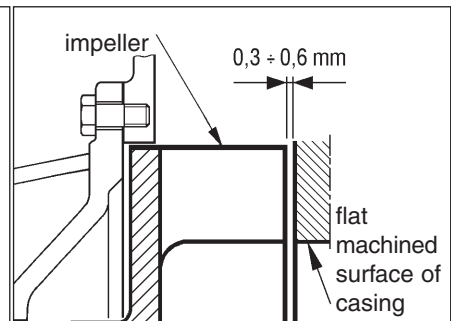

fig. 11

- Remove the lip seal (41)
- Wash the head with solvent to remove any residue of grease and clean the seats of the stationary seal and lip seal thoroughly
- Mount a new lip seal in the head. To facilitate assembly, smear a little oil on the seat and on the outer surface of the lip seal
- Mount the stationary portion of the seal (39) together with its gasket (38). To facilitate this operation, wet the seat on the head and the gasket with methylated spirits. If necessary, use a wooden plunger or similar to push the stationary seal (39) into its seat
- **Reassemble the head taking care not to touch the shaft with the stationary seal seat. If this is ceramic, it could easily break or chip**
- Tighten the head screws (45) and nuts (45.1)
- Smear the gasket of the rotating seal seat (40) and the shaft sleeve (31) with oil and slip the seal on to one end of the shaft sleeve
- Slip the sleeve and seal on to the shaft and push to overcome the slight resistance offered by the lip seal. **Take care that the seal does not slip off the shaft sleeve**
- Mount the seal support ring (25.1). Push this forward until it is possible to reassemble the impeller key (60)
- Reassemble the impeller (03), the impeller washer (66) and tighten the impeller nut (33)
- Check that the distance between the impeller and the flat machined surface in the casing is between 0.3 and 0.6 mm ($A - B = 0.3 - 0.6 \text{ mm}$ - see figs. 9,10,11). Mechanical seals supplied as spare parts have 1 or 2 shims (25.2) which serve to position the impeller further forward if it is too far from the flat machined surface in the casing. The shims should be fitted between the seal support ring (25.1) and the impeller. Further adjustments can be carried out with the casing gaskets and rear wear plate gaskets (where fitted)
- Reassemble the casing gasket (43) after smearing both sides with grease
- Reassemble the casing and tighten the nuts, checking that the impeller is free to rotate
- Fill the seal lubrication chamber (see paragraph 11.1) with grease or oil

12.2.4 Maintenance of the bearings (fig. 5, 6)

The pump is supplied with the bearings already greased and does not require maintenance for the first 500 hours of operation.

The bearings in the bearing housing must be lubricated appropriately, avoiding the use of too much grease which can cause overheating and, as a result, damage to the bearings.

12.2.5 Replacing the bearings

- Empty the pump casing
- Remove the casing, the head and the mechanical seal
- Remove the flexible coupling hub and the shaft key
- Remove the outer bearing cover (08)
- Extract the shaft from the coupling side
- Extract the bearings using a bearing extractor
- To reassemble, proceed in reverse order

12.2.6 Replacing the TWIN-DISC coupling blocks (RBD series)

| Coupling type | Max. speed (RPM) | Max. torque dNm | |
|---------------|------------------|-----------------|-------------------|
| | | Cont. duty | Intermittent duty |
| 8 S | 4500 | 17 | 2 |
| 10 S | 4000 | 31 | 30 |
| 10 SS | 4000 | 31 | 30 |
| 11 S | 3500 | 48 | 62 |
| 14 S | 2800 | 94 | 121 |

- Remove the pump from its seat
- Remove the worn blocks and replace them with new ones
- Check the state of wear of the aluminium flange
- Couple the pump to the engine
- Max. alignment error: 0.7 mm
- When ordering spare rubber blocks, specify the shaft diameter and the type of coupling

12.2.7 Replacing the rubber collar of SURE-FLEX couplings

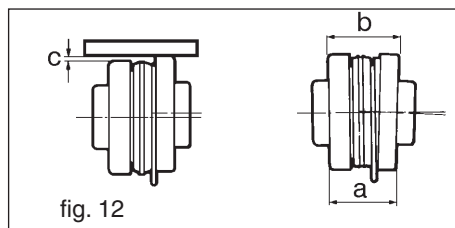
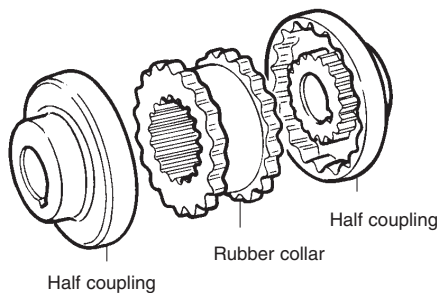

| Coupling type | C mm | (b-a) mm | Torque N m |
|---------------|------|----------|------------|
| J4 | 0,25 | 1,1 | 10 |
| J5 | 0,4 | 1,4 | 20 |
| S6 | 0,4 | 1,8 | 40 |
| S7 | 0,5 | 2,1 | 70 |

- Unscrew the anchor bolts at the base of the pump or motor and separate the two halves of the coupling
- Remove the worn rubber collar and replace it with a new one. In the case of two piece rubber collars (type S) leave the steel ring free to move in one of the two grooves near the indentation
- Move the pump towards the motor and fit the indentation of the half coupling to that of the rubber collar
- Close the coupling leaving an axial play of 2 mm max. for type J couplings and 3 mm max. for type S couplings
- Check the radial and angular alignment as follows:
 - **Radial:** (fig. 12) with a ruler placed on the outer surface of the half couplings, measure the maximum misalignment (dimension C) in at least four points around the circumference and try to bring it as close as possible to zero (see table)
 - **Angular:** (fig. 12) with a gauge, measure at a minimum of four points the distance between the two halves of the coupling and bring the difference (b-a) as close as possible to zero (see table)
- Tighten the anchor bolts at the base of the pump and motor
- When ordering spare parts, specify the type of coupling (stamped on the inside of the half couplings) and the shaft diameter

12.2.8 Replacing the rubber dowels of flexible couplings (fig. 13)

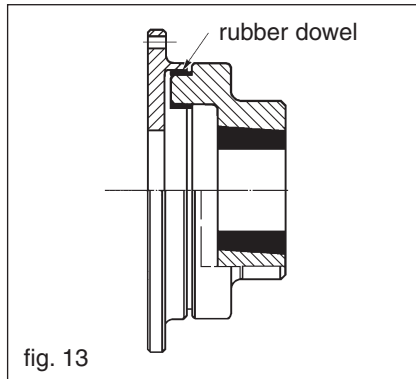

| Coupling type | Max. torque kgm | RPM |
|---------------|-----------------|------|
| 14 | 15 | 4800 |
| 20 | 25 | 4400 |
| 27 | 40 | 4100 |
| 40 | 60 | 3500 |
| 55 | 80 | 3300 |
| 88 | 110 | 3000 |
| 110 | 150 | 2700 |
| 145 | 190 | 2500 |
| 180 | 240 | 2200 |
| 250 | 300 | 2150 |
| 330 | 400 | 2000 |

- Unscrew the anchor bolts at the base of the pump or engine and separate the two halves of the coupling

- Remove the worn dowels and replace them with new ones, fixing them in place with a little adhesive

- Move the pump towards the engine until the coupling is completely closed, then draw it back by 2-3 mm to separate the two halves of the coupling
- Tighten the bolts which anchor the pump and engine to the base plate
- When ordering dowels, specify the diameter of the shaft and the type of coupling

13 OPERATING PROBLEMS: CAUSES AND REMEDIES

Attention: before examining the possible causes of operating problems, ensure that all control instruments (vacuum gauge, pressure gauge, revolution counter, flow recorder, electrical gauges etc.) are working correctly.

13.1 The pump does not prime

- 1 **The pump casing is empty or non sufficiently full**
fill the pump casing through the priming cover or plug (fig. 4)
- 2 **The liquid inside the pump casing is overheated**
add cold liquid to the pump casing through the priming cover or plug (fig. 4)
- 3 **Air leaks in the joints or cracks in the suction line**
Check that couplings and clamps are tight and inspect the suction line
- 4 **Delivery line under pressure**
bleed the delivery line
- 5 **Low rotation speed of the pump**
increase the speed only after having verified the contract data and the pump performance curve
- 6 **The impeller is worn or broken**
check the state of the impeller through the impeller inspection cover, or remove the pump casing as described in paragraph 12.2
- 7 **The cutwater (leading edge of the volute) is worn**
remove the casing as described in paragraph 12.2
- 8 **The suction strainer (if fitted) is clogged**
remove the obstructions
- 9 **The impeller is clogged by foreign objects**
disassemble the casing and remove the foreign objects
- 10 **The suction lift is too high**
reduce the suction lift
- 11 **Air enters through the mechanical seal**
disassemble the seal and clean it (see paragraph 12.2.3); if the problem persists, change the seal

13.2 The pump does not deliver liquid

- 12 **The pump is not primed**
see the points listed under 13.1

- 13 **The head required by the system is greater than the rated head of the pump**
revise the system design or re-select the pump
 - 14 **Excessive friction losses in the suction line**
revise the distribution of elbows, valves, restrictions etc.; if necessary increase the diameter of the pipework
 - 15 **The impeller is clogged by foreign objects**
disassemble the casing and remove the foreign objects
 - 16 **The suction or discharge lines are obstructed or clogged**
locate the obstructed or clogged area and clean
- 13.3 The pump does not have sufficient capacity**
- 17 **Air leaks in the suction line**
check that the couplings are airtight and inspect the suction line
 - 18a **The impeller is worn**
replace the impeller as described in paragraph 12.2.1
 - 18b **The pump casing is worn**
Replace the pump casing after removing the pump from the system as described in paragraphs 15 and 16
 - 19 **The diameter of the suction line is too small**
replace the suction line
Check the other possible causes in paragraph 13.2
- 13.4 The pump does not provide enough pressure**
- 20 **The viscosity of the liquid is higher than expected**
contact the manufacturers after measuring the viscosity; for centrifugal pumps this should not exceed 50 cSt Check other possible causes: see point 5 of paragraph 13.1 and paragraph 13.2
- 13.5 The pump absorbs too much power**
- 21 **The rotation speed is too high**
check the correct rotation speed
 - 22 **The pump operates under conditions which are different for those specified**
check the operating conditions of the pump and compare them to those on the pump name plate
 - 23 **The density of the liquid is higher than specified**
measure the density (or specific gravity) of the liquid and compare it to the agreed figure
 - 24 **Incorrect alignment of the unit**
check that the unit is correctly aligned as described in paragraph 9
 - 25 **Friction inside the pump between the rotating and non rotating components**
remove the pump casing as described in paragraph 12.2 and check if there are signs of rubbing on the surfaces
 - 26 **Foreign bodies trapped in the impeller**
remove the pump casing as described in paragraph 12.2 and remove the foreign bodies
- 13.6 The pump vibrates and is noisy**
- 27 **The pump is operating at too low a capacity**
check the settings of the valves in the system and the readings on the pressure and vacuum gauges
 - 28 **The pump or the pipework are not well fixed**
check that the pipework is correctly clamped
 - 29 **The pump cavitates**
see paragraph 13.2
Check the possible causes in paragraph 13.1

- 30 Foreign bodies trapped in the impeller**
remove the pump casing as described in paragraph 12.2 and remove the foreign bodies

13.7 The pump jams

- 31 Mechanical breakdown**
check the shaft, flexible coupling, motor or engine, pulleys and belts, gear boxes etc. for breakages
- 32 Foreign bodies jammed inside the pump**
remove the pump casing as described in paragraph 12.2

13.8 The bearings have a short lifetime

- 33 Lack of lubrication**
lubricate the bearings as described in paragraph 12.2.5
- 34 Foreign bodies in the bearings**
change the bearings
- 35 The bearings are rusted**
change the bearings

13.9 The mechanical seal leaks

- 36 TW type seal**
this type of seal is suitable for pumping dirty liquids or liquids containing abrasive particles or petroleum products at temperatures up to 110°C; grease every 500 hours through the grease nipple until grease comes out behind the seal. If well lubricated, this seal can run dry for approximately 15 minutes. If the seal leaks during operation, it must be replaced (see paragraph 12.2.4)
- 37 T type seal**
this seal does not require special maintenance. If it leaks, replace it (see paragraph 12.2.3)

13.10 The seal overheats

the pump does not prime (see paragraphs 13.1 - 13.9)

13.11 The elastomer portions of the flexible coupling wear out quickly

Check that the pump is correctly aligned as described in paragraph 9

14 RESIDUAL RISKS

Residual risks are those which cannot be eliminated through the pump design:

- knocks
- anomalous pressure rises
- misuse
- manoeuvring errors in the vicinity of the pump.

15 REPAIRS

Before carrying out repairs on the pump it is essential to:

- turn off the mains power (follow the directions in paragraph 12)
- close the gate valves on the suction and discharge sides of the pump
- if the pumped liquid is hot, wait until the pump has cooled down to ambient temperature
- **if the pumped liquid is hazardous, follow the safety procedures for handling hazardous liquids**
- **empty the pump casing through the drain plug (68.2) (see paragraph 12.2)**
- remove and clean any residues of the pumped liquid

16 DISASSEMBLY

16.1 Removing the pump from the system

Carry out the instructions in paragraph 15

- remove the nuts of the suction and discharge flanges
- remove the bolts which fix the pump to the base plate
- slip the pump out of the flexible coupling (if fitted) or remove it from the electric motor
- before lifting the pump with appropriate lifting devices, check the weight of the pump shown on the name plate

17 ASSEMBLY

17.1 Mounting the pump in the system

- lift the pump using suitable lifting devices
- position the pump on the base plate
- reconnect to the flexible coupling or electric motor
- check the alignment as described in paragraph 9
- fix the pump to the base plate
- connect the pump to the pipework
- remount any coupling guards fitted

18 SPARE PARTS

To ensure that the pump continues to operate well as time goes on, it is advisable, when ordering the pump, to acquire the spare parts recommended for the first maintenance operation:

- mechanical seal
- impeller
- set of gaskets
- check valve
- self-locking impeller nut

18.1 Ordering spare parts

To order spare parts, specify the following:

- type of pump
- serial number of the pump
- reference number and description of the part as shown in the exploded drawing

19 DISPOSAL

- Do not abandon in the environment
- Metal parts can be recycled as scrap
- Grease and oil must be recovered and stored as prescribed by the relevant legislation for disposal by approved agencies
- Elastomer gaskets must be removed and disposed of in an approved waste disposal unit.



VARISCO POMPE S.r.l.

Zona Industriale Nord - Terza Strada, 9 - 35129 PADOVA - Italy

Tel. +39 049 82 94 312 - Fax +39 049 80 76 762 - e-mail: export@variscopompe.com

Web site : www.variscopompe.com