

ConceptSQ

Cleaner by Design

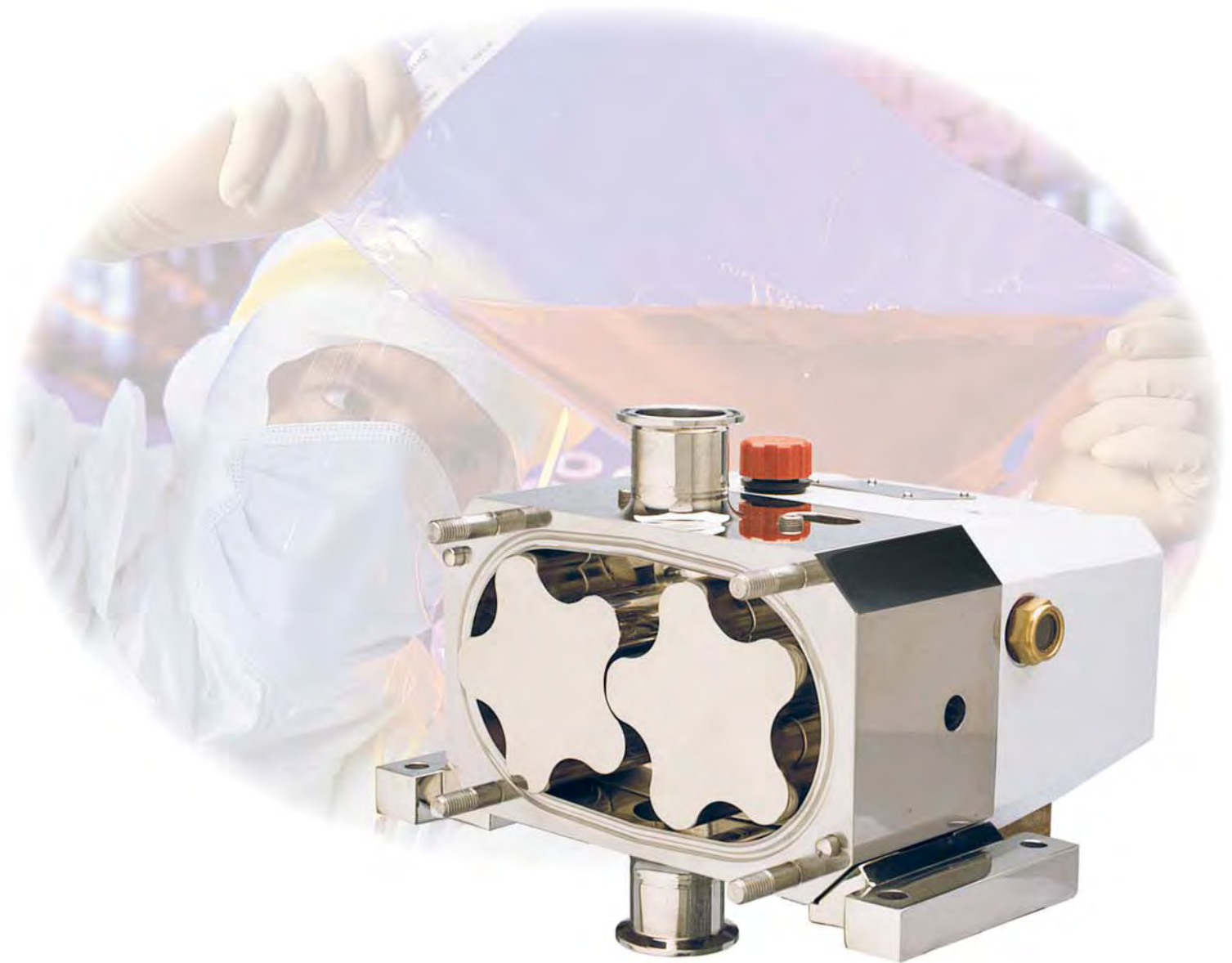

An Original Quality Product from
JOHNSON PUMP [UK]

IPX
IDEX CORPORATION

A Subsidiary of Viking Pump Inc.
A Unit of IDEX Corporation



Concept SQ

THE NEED FOR A CLEANER PROCESS ENVIRONMENT

With the introduction of new processing technologies to meet consumer demand for highly sophisticated products, greater cost pressures and an increasingly complex international regulatory framework, control of the process environment is more important than ever before.

Today's hygiene-critical technologies are far more exacting; the need to quantify and control micro-organism growth accurately and efficiently is of paramount importance.

The consequences of contamination are far too serious to risk. As well as wasting valuable resources, spoilt product is expensive to dispose of and, as recent cases have shown, the repercussions of contamination reaching the consumer can be catastrophic.

Legislative changes for consumer and environmental protection, both domestic and international, are imposing ever-stricter manufacturing standards. In a competitive market, the worldwide quest for improved product quality is never-ending.

Yet as a manufacturer, you're also under constant pressure to maximise productivity. To meet tougher cost controls, production lines have to be run for longer periods. More products have to be accommodated on fewer lines - and that means achieving faster repeatable cleaning and shorter change-over intervals.

Whatever your process, the pump is at the heart. The only way to satisfy all these sometimes conflicting demands is with a pump concept that from the outset has been designed to minimise cross-contamination and resulting microbial growth - effectively, economically and with the utmost reliability.

THE SOLUTION: CONCEPT SQ

Hence Concept SQ - the definitive pump for critical hygiene applications and those requiring aseptic, sterile or clean process environments.

The SQ range was designed from the start to eliminate potential product-retaining areas in the flow path through the pump and, where required, to provide the facility for permanent sterile barriers at all product/atmosphere interfaces.



Concept SQ is unique in offering specification flexibility that combines sterile barriers with front-loading single or double mechanical seals, external rotor fixing and superb self-draining characteristics. As a result, the range delivers benchmark CIP and SIP performance, together with the simplicity of maintenance to assure minimum downtime.

Front loading single, single flushed and double flushed mechanical seals are positioned directly behind the rotor maximising drainage from and cleaning of the seal area.

Internal corners in the flow path through the pump are radiussed to minimise product retention and give optimum effective cleaning performance. Product-wetted surfaces are of 316L low carbon stainless steel for improved corrosion resistance and minimum carbon migration, finished to the standards required for application acceptance.

Inlet and outlet ports can be finished to a variety of clamp, thread or flange standards, with aseptic fittings available where barrier circulation is required to ensure that the process environment is reliably maintained.



Concept SQ Pump with optional Stainless Steel Gear Cover

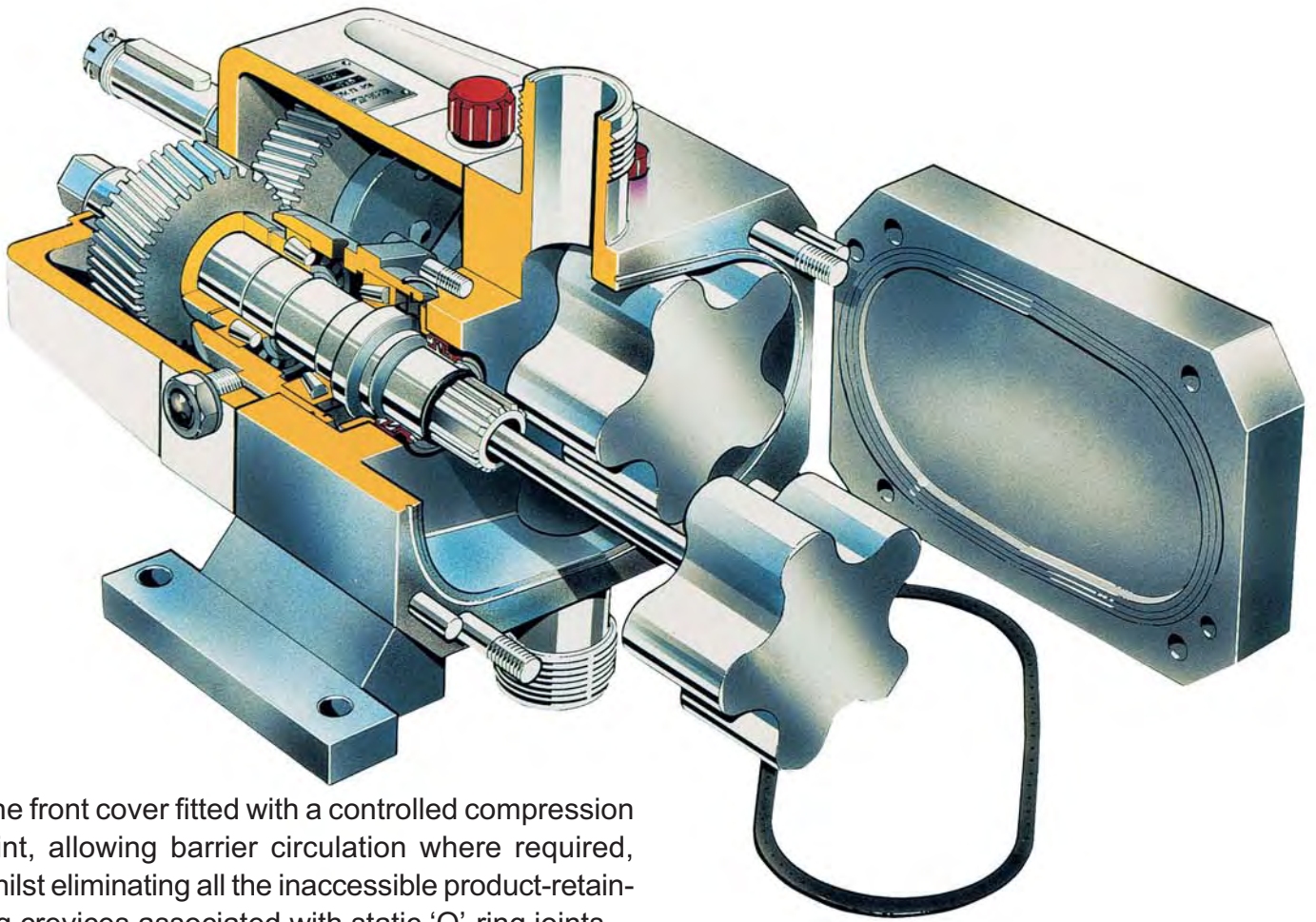

The front cover fitted with a controlled compression joint, allowing barrier circulation where required, whilst eliminating all the inaccessible product-retaining crevices associated with static 'O'-ring joints.

New multi-lobe rotors with internal location and drive are retained from outside the pumping chamber to eliminate the crevices associated with conventional fixing methods for optimum cleanability.

All potential entry and exit points at the product/atmosphere interfaces can be serviced with a steam or fluid barrier to ensure that product integrity and required containment are continuously maintained for maximum process control and assured operator/environmental safety.

APPLICATION VERSATILITY

Together, these features deliver tremendous operational benefits across a broad spectrum of applications.

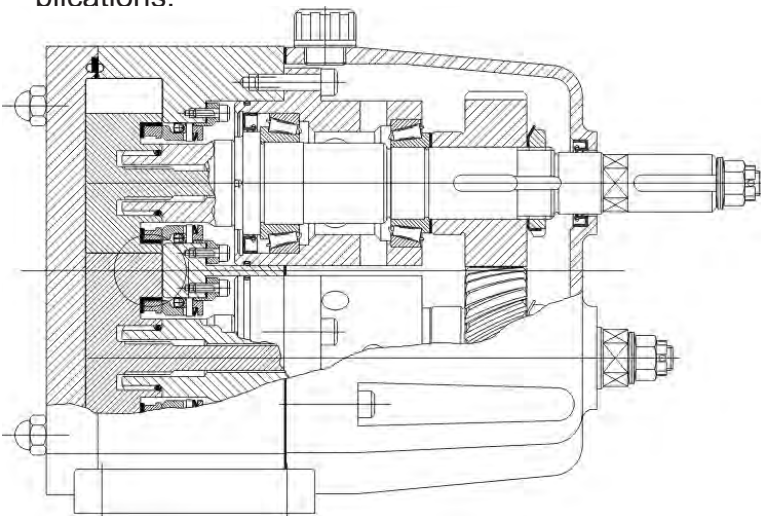

The Concept SQ pump led the market with the first Campden & Chorleywood Food Research Association's derived EHEDG certification. The pump has been tested for CIP cleanability at the CCFRA facility and was successfully certified according to the EHEDG CIP Test Protocol.

The Concept SQ was also the first pump that CCFRA certified according to the EHEDG methods for the assessment of in-line steam sterilisability and bacteria tightness of processing equipment and has gone on to be used in noxious vaccine production where bacteria tightness is paramount.

Concept SQ

APPLICATIONS

• FOOD

Baby foods, dairy products, fruit juices, low-fat spreads, yoghurts and ice creams.

• PERSONAL HYGIENE PRODUCTS

Lotions, moisturisers, cosmetics, aqueous emulsions, actives and hair care products.

• BIO-TECHNOLOGY

Fermentation cell broths, pyrogen-free liquids, intermediates, antibodies and micro-organisms for containment.

• PHARMACEUTICAL

Sterile injectables, aqueous creams, ointments, vaccines, blood products and sterile sugars.

• CHEMICAL

Flavourings, fragrances, colourings, inks, detergents and organic compounds.

• ELECTRONIC AND PHOTOGRAPHIC

Etching agents, cleaning fluids, developers and emulsions.

Operating Parameters & Specifications

4 Frame sizes - 8 displacements

Max Flow: 109 m³/h

Max Pressure: 15 bar

Max Viscosity: 500,000 cP

Port Sizes: 25 - 100 mm (1.0" - 4.0")

Contact Materials 316L stainless Steel.

Mechanical Seals:

Silicon Carbide/Silicon Carbide

Elastomers:

EPDM/FDA

Viton®/FDA

Mechanical seals available as single, single low pressure flushed or double high pressure flush.

Steam of sterile fluid barrier seals available for front cover and inlet/outlet ports.

Standard machined internal surface finish to 0.8 µRa or better. Improved finishes and electro-polishing available.

OPERATING PARAMETERS

	Litres/rev	Imperial Gal/rev	US Gal/rev	Port Size mm	Port Size Inch	Max Bar	Max PSI	Max RPM
SQ1/0004/12	0.04	0.088	1.06	25	1.0	12	175	1000
SQ1/0007/06	0.07	1.760	2.11	25	1.0	6	85	1000
SQ2/0017/15	0.17	3.740	4.49	40	1.5	15	215	850
SQ2/0030/07	0.30	6.600	7.93	50	2.0	7	100	850
SQ3/0054/15	0.54	11.88	14.27	50	2.0	15	215	700
SQ3/0103/07	1.03	22.66	27.21	80	3.0	7	100	700
SQ4/0160/15	1.60	35.20	42.27	80	3.0	15	215	600
SQ4/0303/07	3.03	66.66	80.06	100	4.0	7	100	600

From the manufacturers of the On-Line, Classic, AccuLobe, Steri-Lobe, SQ and RTP Pump



JOHNSON PUMP (UK) LTD.
Eastbourne, England, BN23 6PT
Tel: +44 (0)1323 509211
Fax: +44 (0)1323 507306
Email: jinjo@idexcorp.com
<http://www.johnsonpump.com>

