

## Air Operated Diaphragm Pump



**Max Flow: 230 GPM @100 psi**

## FEATURES

- **Stall-Free Design** – Our “posi-shift”, tandem spool air distribution valve insures reliable operation in all types of low pressure and start/stop applications. In addition, fewer parts and no o-rings result in easier maintenance.
- **Oil-less Air Valve** – No metal-to-metal wearing surfaces. State-of-the-art materials and precision manufacturing techniques provide the industry’s original completely oil-less design. This design means no oil misting into the environment that would create an unhealthy working condition, and no oil, lubricants or grease to contaminate your products. Our oil-less design results in lower operating and maintenance costs. This design has been field proven and working trouble-free since 1984.
- **Externally Serviceable Air Valve** – No need to disassemble the pump for routine maintenance. The air valve can be quickly and easily maintained with minimal downtime.
- **Variety of Elastomers** - AOD<sup>®</sup> pumps can be assembled with the elastomer that matches your application; Neoprene, Buna-N, Nordel<sup>®</sup>, Teflon<sup>®</sup>, Santoprene<sup>®</sup>, and Viton<sup>®</sup> are all available.

**Also Available In Clamped Design!**

## AOD3 - \*(-A, -S) -B

### \*Pump Body Materials

- A - Aluminum
- S - Stainless Steel

### Elastomers

- Buna-N
- Neoprene
- Nordel<sup>®</sup>
- Santoprene<sup>®</sup>
- Teflon<sup>®</sup>
- Viton<sup>®</sup>

### Applications

- Aircraft Industry
- Automotive
- Beverage Industry
- Chemical and Petroleum
- Glass and Fiberglass
- Marine
- Metal and Steel
- Mine and Construction
- Paint
- Paper and Wood

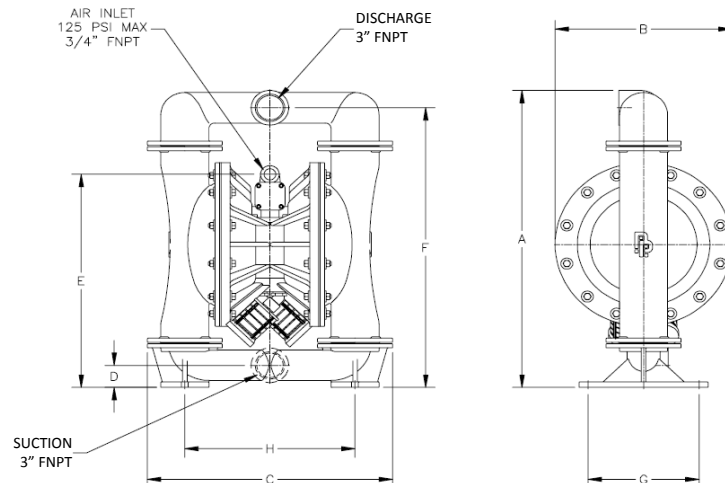

MODEL (Dimensions)		Aluminum	Stainless Steel
		AOD3-Axxx-B	AOD3-Sxxx-B
<b>SUCTION (Bottom)</b>	Inches	<b>3 FNPT, BSP</b>	<b>3 FNPT, BSP</b>
<b>DISCHARGE (Top)</b>	Inches	<b>3 FNPT, BSP</b>	<b>3 FNPT, BSP</b>
<b>A – Total Height</b>	Inches (mm)	29.5 (749)	29.5 (749)
<b>B – Total Depth</b>	Inches (mm)	14.75 (375)	14.75 (375)
<b>C – Total Width</b>	Inches (mm)	20.13 (511)	20.13 (511)
<b>Air Inlet Size</b>		<b>3/4" FNPT</b>	<b>3/4" FNPT</b>
<b>Air Exhaust Size</b>		<b>3/4" FNPT</b>	<b>3/4" FNPT</b>
<b>D – Suction</b>	Inches (mm)	2.5 (64)	2.5 (64)
<b>E – Air Inlet</b>	Inches (mm)	20.31 (516)	20.31 (516)
<b>F – Discharge</b>	Inches (mm)	27.38 (695)	27.38 (695)
<b>G – Mounting</b>	Inches (mm)	9.25 (235)	9.25 (235)
<b>H – Mounting</b>	Inches (mm)	14.88 (378)	14.88 (378)

NOTE: Pump dimensions may vary depending on configuration. Dimensions are to be used for reference only.



AOD<sup>®</sup> is a registered trademark of Price<sup>®</sup> Pump Co.; Teflon<sup>®</sup> is a registered trademark of DuPont; Viton<sup>®</sup> and Nordel<sup>®</sup> are registered trademarks of DuPont Dow Elastomers; Santoprene<sup>®</sup> is a registered trademark of Monsanto Company.

# AOD3 -A, -S (-B)

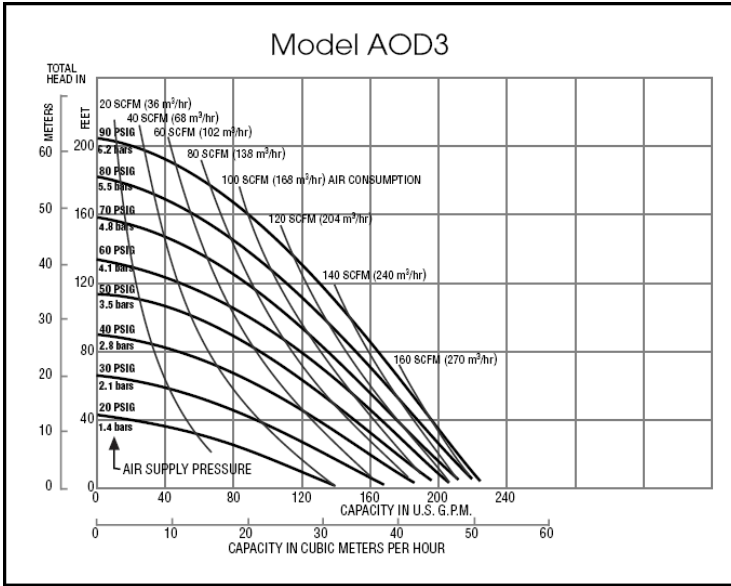

Technical Data		
<b>Maximum flow</b>	GPM (liters per minute)	230 (871)
<b>Displacement/Stroke</b>	Gal (liters)	
Elastomer Diaphragms		0.87 (3.3)
Teflon® Diaphragms		0.82 (3.1)
<b>Max Air Inlet Pressure</b>	PSI (bar)	125 (8.8)
<b>Max Spherical Solids Size</b>	IN (mm)	7/16 (11)
<b>High Liquid Temp. Limit</b>	*(See elastomer specs. below)	
<b>Low Liquid Temp. Limit</b>	°F (°C)	32 (0)
<b>Shipping Weight</b>	Lbs (kg)	
Aluminum		138 (63)
Stainless Steel		230 (104)

*Elastomers		
Maximum Liquid Temperature		
MATERIAL	AL, SS	Kit P/N
Buna-N	180°F (82°C)	45-332-10
Neoprene	180°F (82°C)	45-332-00
Nordel®	180°F (82°C)	45-332-30
Santoprene®	212°F (100°C)	45-332-60
Teflon® AL, SS	212°F (100°C)	46-438-56
Viton®	248°F (120°C)	45-332-20

Materials of Construction		
Bolted Series	Stainless Steel	Aluminum
<b>Air Valve Housing</b>	Anodized Aluminum	
<b>Air Chambers</b>	Aluminum	Aluminum
<b>Pump Chambers</b>	Stainless Steel	Aluminum
<b>Spool Housing</b>	Anodized Aluminum	
<b>Pump External Finish</b>	Natural (Not Painted)	
<b>Valve Type</b>	Elastomeric Ball	
Optional: Polypro Air Valve Assembly with SS Spool Housing		

Suction Lifts				
Elastomer Type (Material)	Dry Prime FT (meters)		Wet Prime FT (meters)	
Standard (AL, SS)	11	(3.4)	13	(4.0)
Teflon® (AL, SS)	11	(3.4)	13	(4.0)

Your Local Price® Pump Distributor:

The performance curves shown and other published literature reflect an average performance for all materials and all elastomers, including Teflon®. Derating of the performance is not necessary for Teflon® fitted pumps.

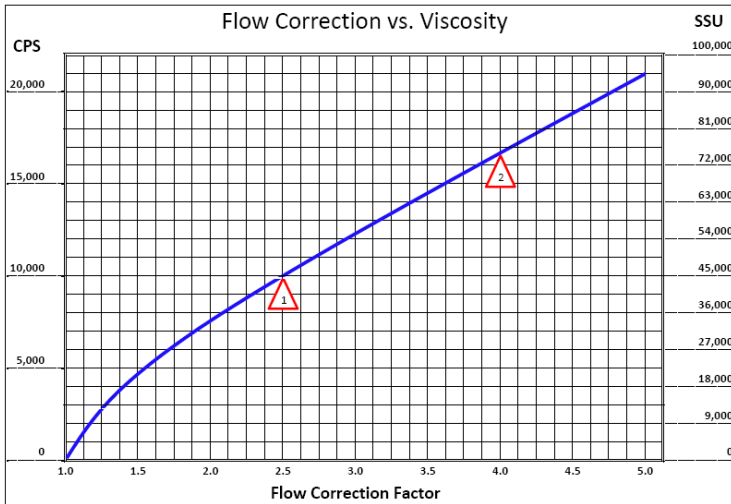

To determine the correction flow rate, find the intersection of the VISCOSITY on the above curve and read the FLOW CORRECTION FACTOR. Multiply this factor by the desired flow of the pump and use this new flow rate to select a pump from the performance curves.

Example  $\Delta$  10,000 CPS = 2.5 Flow Correction Factor.  
If viscous flow desired is 42 GPM, then multiply 42 by 2.5 = 105 (GPM equivalent water flow)

Example  $\Delta$  74,000 SSU = 4.0 Flow Correction Factor.  
If viscous flow desired is 35 GPM, then multiply 35 by 4.0 = 140 (GPM equivalent water flow)



21775 Eighth Street East,  
Sonoma, CA 95476-0329  
MAIN (707) 938-8441  
TOLL FREE (800) 345-PUMP (7867)  
FAX (707) 938-0764  
[www.pricepump.com](http://www.pricepump.com)  
E-mail: [sales@pricepump.com](mailto:sales@pricepump.com)

