



## Air Operated Diaphragm Pump



**Max Flow: 27.3 GPM @100 psi**

### FEATURES

- **Stall-Free Design** – A patented non-centering, spring assisted shifter is incorporated into every “Y” series pump, ensuring a positive shift every time. All “Y” series pumps eliminate the need of pre-packing or extended lubrication.
- **Oil-less Operation** – Oil-less operation “Y” series pumps incorporate no metal-to-metal wearing surfaces. This design means no oil misting into the environment that would create an unhealthy working condition, and no oil, lubricants or grease to contaminate your products. Our oil-less design results in lower operating and maintenance costs.
- **Quiet Operation** – Air valve design minimizes exhaust noise providing a significantly quieter work environment.
- **Portable/Simple Installation** – Simply connect your air supply line and liquid lines; the pump is now ready to perform. There are no complex controls to install and operate.
- **Submersible** – If external components are compatible, these pumps can be submerged in the liquid by simply running the exhaust line above the liquid level.

## AOD.75 - \*(-P)

### \*Pump Body Materials

P – Polypropylene †

### Elastomers

Buna-N	Santoprene®
Neoprene	Teflon®
Nordel®	Viton®

### Applications

- Aircraft Industry
- Automotive
- Beverage Industry
- Chemical and Petroleum
- Glass and Fiberglass
- Marine
- Metal and Steel
- Mine and Construction
- Paint
- Paper and Wood

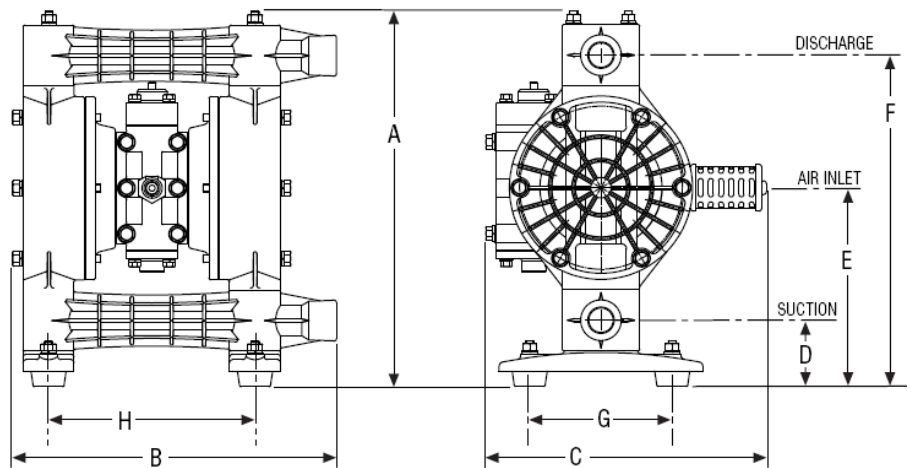

MODEL (Dimensions)		Polypropylene AOD.75-Pxxx-Y
<b>SUCTION (Bottom)</b>	Inches	<b>3/4 FNPT, BSP</b>
<b>DISCHARGE (Top)</b>	Inches	<b>3/4 FNPT, BSP</b>
<b>A – Total Height</b>	Inches (mm)	14.49 (368)
<b>B – Total Depth</b>	Inches (mm)	12.44 (316)
<b>C – Total Width</b>	Inches (mm)	10.93 (278)
<b>Air Inlet Size</b>		<b>1/4" FNPT</b>
<b>Air Exhaust Size</b>		<b>3/4" FNPT</b>
<b>D – Suction Dimension</b>	Inches (mm)	2.60 (66)
<b>E – Air Inlet Dimension</b>	Inches (mm)	7.68 (195)
<b>F – Discharge Dimension</b>	Inches (mm)	12.8 (324)
<b>G – Mounting Dimension</b>	Inches (mm)	4.92 (125)
<b>H – Mounting Dimension</b>	Inches (mm)	7.99 (203)

NOTE: Pump dimensions may vary depending on configuration. Dimensions are to be used for reference only.



AOD® is a registered trademark of Price® Pump Co.; Teflon® is a registered trademark of DuPont; Viton® and Nordel® are registered trademarks of DuPont Dow Elastomers; Santoprene® is a registered trademark of Monsanto Company.

† Material is not ATEX certified.

# AOD.75 -P

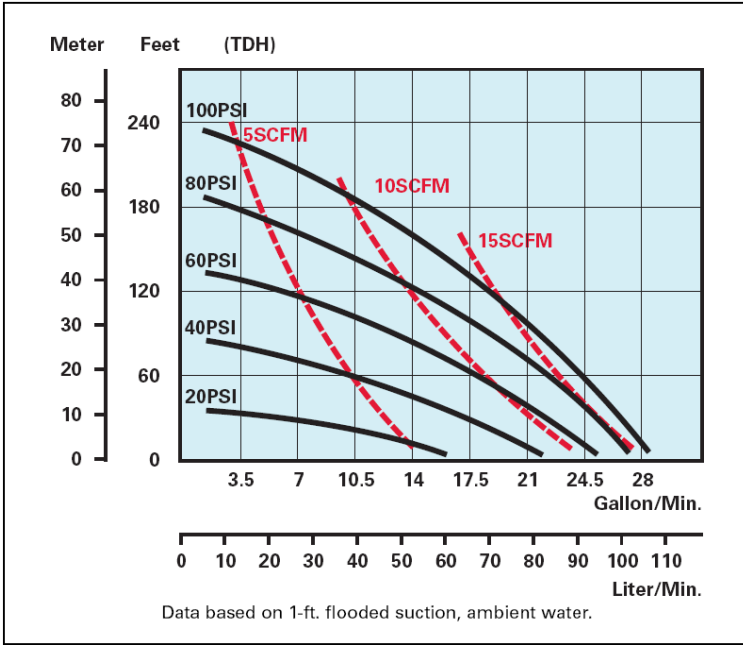

The performance curves shown and other published literature reflect an average performance for all materials and all elastomers, including Teflon®. Derating of the performance is not necessary for Teflon® fitted pumps.

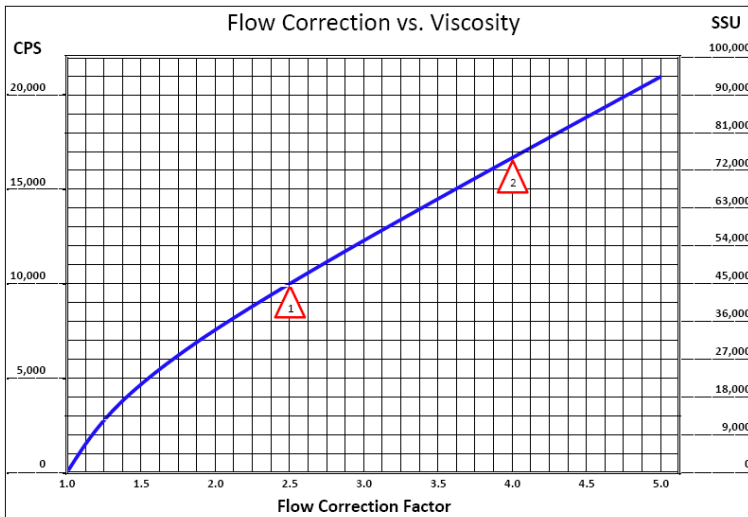

To determine the correction flow rate, find the intersection of the VISCOSITY on the above curve and read the FLOW CORRECTION FACTOR. Multiply this factor by the desired flow of the pump and use this new flow rate to select a pump from the performance curves.

Example  $\Delta$  10,000 CPS = 2.5 Flow Correction Factor.  
If viscous flow desired is 42 GPM, then multiply 42 by 2.5 = 105 (GPM equivalent water flow)

Example  $\Delta$  74,000 SSU = 4.0 Flow Correction Factor.  
If viscous flow desired is 35 GPM, then multiply 35 by 4.0 = 140 (GPM equivalent water flow)

**PRICE®  
PUMP CO.**

21775 Eighth Street East,  
Sonoma, CA 95476-0329  
MAIN (707) 938-8441  
TOLL FREE (800) 345-PUMP (7867)  
FAX (707) 938-0764  
[www.pricepump.com](http://www.pricepump.com)  
E-mail: [sales@pricepump.com](mailto:sales@pricepump.com)

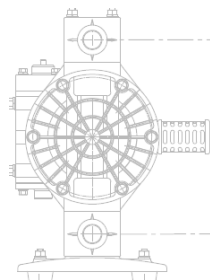

Member of:  
**Hydraulic  
INSTITUTE**

## Technical Data

<b>Maximum flow</b>	GPM (liters per Minute)	27.3 (103)
<b>Displacement/Stroke</b>		
Elastomer Diaphragms	Gal (liters)	0.14 (0.53)
Teflon® Diaphragms		0.10 (0.38)
<b>Max Air Inlet Pressure</b>	PSI (bar)	100 (6.9)
<b>Max Spherical Solids Size</b>	IN (mm)	1/16 (2)
<b>High Temperature Limit</b>	°F (°C)	180 (82)
<b>Low Temperature Limit</b>	°F (°C)	40 (4.44)
<b>Shipping Weight</b>	Lbs (kg)	
Polypropylene		22.6 (10.25)

## Elastomer Kits

Maximum Liquid Temperature

MATERIAL	Polypropylene	P/N
Buna-N	180°F (82°C)	K20-PN
Neoprene	180°F (82°C)	K20-PC
Nordel®	180°F (82°C)	K20-PE
Santoprene®	180°F (82°C)	K20-PS
Teflon®	180°F (82°C)	K20-PT
Viton®	180°F (82°C)	K20-PV

## Materials of Construction

<b>Air Valve Housing</b>	Aluminum
<b>Air Chambers</b>	Aluminum
<b>Spool Housing</b>	Aluminum
<b>Pump External Finish</b>	Natural (Not Painted)
<b>Valve Type</b>	Elastomeric Ball

## Suction Lift

<b>Elastomer Type (Material)</b>	<b>Dry Prime</b>
Standard (Polypro)	18 Feet (5.48 meters)

Your Local Price® Pump Distributor: