



Air Operated Diaphragm Pump



Max Flow: 15 GPM @100 psi

FEATURES

- **Stall-Free Design** – Our “posi-shift”, tandem spool air distribution valve insures reliable operation in all types of low pressure and start/stop applications. In addition, fewer parts and no o-rings result in easier maintenance.
- **Oil-less Air Valve** – No metal-to-metal wearing surfaces. State-of-the-art materials and precision manufacturing techniques provide the industry’s original completely oil-less design. This design means no oil misting into the environment that would create an unhealthy working condition, and no oil, lubricants or grease to contaminate your products. Our oil-less design results in lower operating and maintenance costs. This design has been field proven and working trouble-free since 1984.
- **Externally Serviceable Air Valve** – No need to disassemble the pump for routine maintenance. The air valve can be quickly and easily maintained with minimal downtime.
- **Variety of Elastomers** - AOD® pumps can be assembled with the elastomer that matches your application; Neoprene, Buna-N, Nordel®, Teflon®, Santoprene®, and Viton® are all available.

AOD.50 - *(-P, -K)

*Pump Body Materials

- P - Polypropylene
- K - Kynar® (PVDF) †

Elastomers

- Buna-N
- Neoprene
- Nordel®
- Santoprene®
- Teflon®
- Viton®

Applications

- Aircraft Industry
- Automotive
- Beverage Industry
- Chemical and Petroleum
- Glass and Fiberglass
- Marine
- Metal and Steel
- Mine and Construction
- Paint
- Paper and Wood

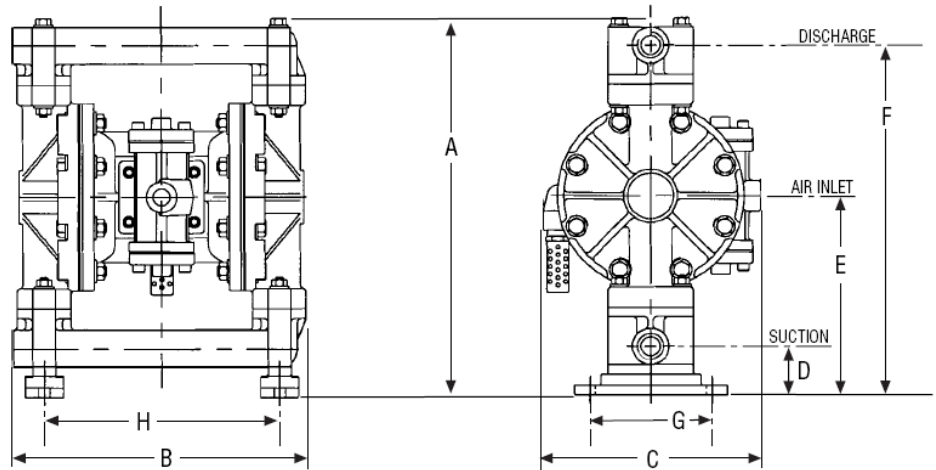

MODEL (Dimensions)		Polypropylene	Kynar®
		AOD.5-PxxP	AOD.5-KxxK
SUCTION (Bottom)	Inches	1/2 FNPT, BSP	1/2 FNPT, BSP
DISCHARGE (Top)	Inches	1/2 FNPT, BSP	1/2 FNPT, BSP
A – Total Height	Inches (mm)	12.38 (314)	12.06 (306)
B – Total Depth	Inches (mm)	9.56 (243)	9.38 (238)
C – Total Width	Inches (mm)	7.5 (191)	7.5 (191)
Air Inlet Size		3/8" FNPT	3/8" FNPT
Air Exhaust Size		1/2" FNPT	1/2" FNPT
D – Suction Dimension	Inches (mm)	1.63 (41)	1.63 (41)
E – Air Inlet Dimension	Inches (mm)	6.56 (167)	6.44 (164)
F – Discharge Dimension	Inches (mm)	11.5 (292)	11.31 (287)
G – Mounting Dimension	Inches (mm)	4 (102)	4 (102)
H – Mounting Dimension	Inches (mm)	7.69 (195)	7.69 (195)

NOTE: Pump dimensions may vary depending on configuration. Dimensions are to be used for reference only.



AOD® is a registered trademark of Price® Pump Co.; Teflon® is a registered trademark of DuPont; Viton® and Nordel® are registered trademarks of DuPont Dow Elastomers; Santoprene® is a registered trademark of Monsanto Company.

† Material is not ATEX certified.

AOD.5 -P, -K

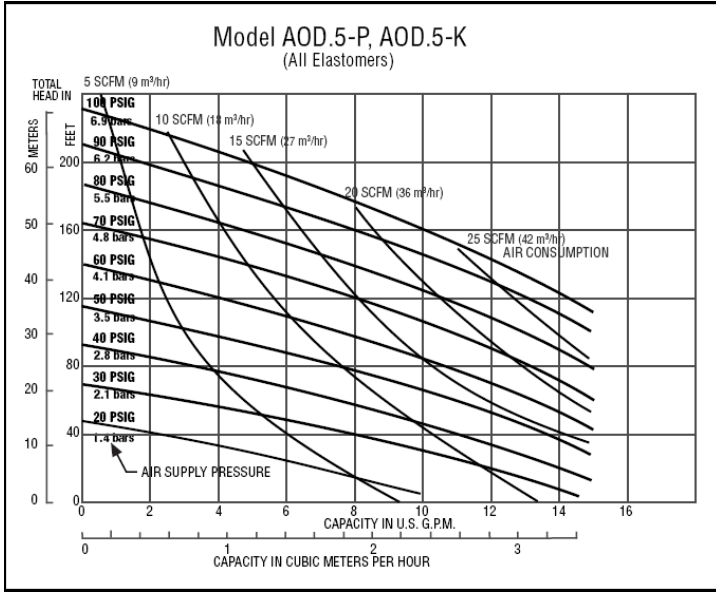

The performance curves shown and other published literature reflect an average performance for all materials and all elastomers, including Teflon®. Derating of the performance is not necessary for Teflon® fitted pumps.

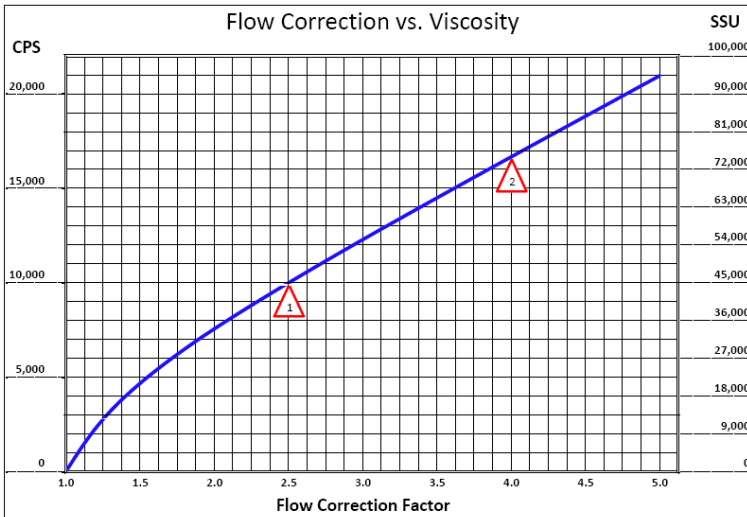

To determine the correction flow rate, find the intersection of the VISCOSITY on the above curve and read the FLOW CORRECTION FACTOR. Multiply this factor by the desired flow of the pump and use this new flow rate to select a pump from the performance curves.

Example \triangle 10,000 CPS = 2.5 Flow Correction Factor.

If viscous flow desired is 42 GPM, then multiply 42 by 2.5 = 105 (GPM equivalent water flow)

Example \triangle 74,000 SSU = 4.0 Flow Correction Factor.

If viscous flow desired is 35 GPM, then multiply 35 by 4.0 = 140 (GPM equivalent water flow)

Technical Data		
Maximum flow	GPM (liters per Minute)	15 (57)
Displacement/Stroke	Gal (liters)	
	Elastomer Diaphragms	0.016 (0.06)
	Teflon® Diaphragms	0.014 (0.05)
Max Air Inlet Pressure	PSI (bar)	125 (8.8)
Max Spherical Solids Size	IN (mm)	1/8 (3.2)
High Liquid Temp. Limit	*(See elastomer specs. below)	
Low Temperature Limit	°F (°C)	32 (0)
Shipping Weight	Lbs (kg)	
	Polypro	39 (17.7)
	Kynar®	39 (17.7)

*Elastomers			
Maximum Liquid Temperature			
MATERIAL	Polypro	Kynar®	Kit P/N
Buna-N	180°F (82°C)	180°F (82°C)	46-440-10
Neoprene	180°F (82°C)	180°F (82°C)	46-440-00
Nordel®	180°F (82°C)	180°F (82°C)	46-440-30
Santoprene®	180°F (82°C)	212°F (100°C)	46-440-60
Teflon®	180°F (82°C)	212°F (100°C)	46-440-55
Viton®	180°F (82°C)	248°F (120°C)	46-440-20

Materials of Construction	
Air Valve Housing	Polypro-glass filled
Air Chambers	Polypro-glass filled / Kynar®
Spool Housing	Electroless Nickel Coated Aluminum
Pump External Finish	Natural (Not Painted)
Valve Type	Elastomeric Ball

Suction Lifts				
Elastomer Type (Material)	Dry Prime		Wet Prime	
	FT (meters)	FT (meters)	FT (meters)	FT (meters)
Standard	13 (4.0)	21 (6.4)	21 (6.4)	21 (6.4)
Teflon®	13 (4.0)	21 (6.4)	21 (6.4)	21 (6.4)



21775 Eighth Street East,
Sonoma, CA 95476-0329
MAIN (707) 938-8441
TOLL FREE (800) 345-PUMP (7867)
FAX (707) 938-0764
www.pricepump.com
E-mail: sales@pricepump.com

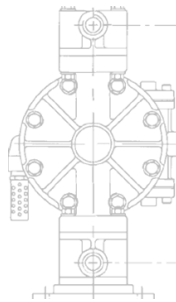

Your Local Price® Pump Distributor: