

Pompa tipo Pump size	Motore - Motor		Base Base- Plate n.°	DIMENSIONI - DIMENSIONS (mm.)																	Peso * Weight kg
	Grand. Size	KW		DNa	DNm	a	f	h3	h2	L1	L2	L3	B2	B3	w	d	b	c1	c2	T*	
RN 32/125F	71 B2	0,55	1	50	32	80	360	172	140	750	120	510	350	320	60	14	6	0	41	685	55
RN 32/125D	80 A2	0,75	1	"	"	"	"	"	"	"	"	"	"	"	60	"	"	0	32	715	60
RN 32/125A	80 B2	1,1	1	"	"	"	"	"	"	"	"	"	"	"	60	"	"	0	32	715	61
RN 32/125S	90 S2	1,5	1	"	"	"	"	"	"	"	"	"	"	"	60	"	"	0	22	740	65
RN 32/160B	90 S2	1,5	1	50	32	80	360	192	160	750	120	510	350	320	60	14	6	0	42	740	70
RN 32/160A	90 L2	2,2	1	"	"	"	"	"	"	"	"	"	"	"	60	"	"	0	42	765	75
RN 32/200D	90 L2	2,2	1	50	32	80	360	220	180	750	120	510	350	320	60	14	6	0	70	765	80
RN 32/200C	100 L2	3	1	"	"	"	"	"	"	"	"	"	"	"	60	"	"	0	60	805	85
RN 32/200A	112 M2	4	1	"	"	"	"	"	"	"	"	"	"	"	60	"	"	0	48	805	90
RN 40/125F	80 B2	1,1	1	65	40	80	360	172	140	750	120	510	350	320	60	14	6	0	32	715	65
RN 40/125C	90 S2	1,5	1	"	"	"	"	"	"	"	"	"	"	"	60	"	"	0	22	740	65
RN 40/125A	90 L2	2,2	1	"	"	"	"	"	"	"	"	"	"	"	60	"	"	0	22	765	70
RN 40/160C	90 L2	2,2	1	65	40	80	360	192	160	750	120	510	350	320	60	14	6	0	42	765	75
RN 40/160B	100 L2	3	1	"	"	"	"	"	"	"	"	"	"	"	60	"	"	0	32	805	80
RN 40/160A	112 M2	4	1	"	"	"	"	"	"	"	"	"	"	"	60	"	"	0	20	805	85
RN 40/200C	112 M2	4	1	65	40	100	360	220	180	750	120	510	350	320	60	14	6	0	48	825	95
RN 40/200B	132SA2	5,5	2	"	"	"	"	280	"	1000	170	660	400	360	60	19	30	0	28	910	130
RN40/200AR	132SA2	5,5	2	"	"	"	"	"	"	"	"	"	"	"	60	"	"	0	28	910	130
RN 40/200A	132SB2	7,5	2	"	"	"	"	"	"	"	"	"	"	"	60	"	"	0	28	910	135
RN 40/250B	160MA2	11	2	65	40	100	360	300	225	1000	170	660	400	360	75	19	30	0	20	1065	180
RN 40/250A	160MB2	15	2	"	"	"	"	"	"	"	"	"	"	"	75	"	"	0	20	1065	190
RN 50/125F	90 L2	2,2	1	65	50	100	360	192	160	750	120	510	350	320	60	14	6	0	42	785	80
RN 50/125D	100 L2	3	1	"	"	"	"	"	"	"	"	"	"	"	60	"	"	0	32	825	85
RN 50/125A	112 M2	4	1	"	"	"	"	"	"	"	"	"	"	"	60	"	"	0	20	825	90
RN 50/160B	132SA2	5,5	2	65	50	100	360	280	180	1000	170	660	400	360	60	19	30	0	28	910	125
RN 50/160A	132SB2	7,5	2	"	"	"	"	"	"	"	"	"	"	"	60	"	"	0	28	910	130
RN 50/200B	132MA2	9,2	2	65	50	100	360	280	200	1000	170	660	400	360	60	19	30	0	28	910	145
RN 50/200A	160MA2	11	2	"	"	"	"	"	"	"	"	"	"	"	60	"	"	0	0	1065	170
RN 50/250B	160MB2	15	2	65	50	100	360	300	225	1000	170	660	400	360	75	19	30	0	20	1065	195
RN 50/250A	160 L2	18,5	2	"	"	"	"	"	"	"	"	"	"	"	75	"	"	0	20	1065	205

* Variabile a seconda del costruttore del motore

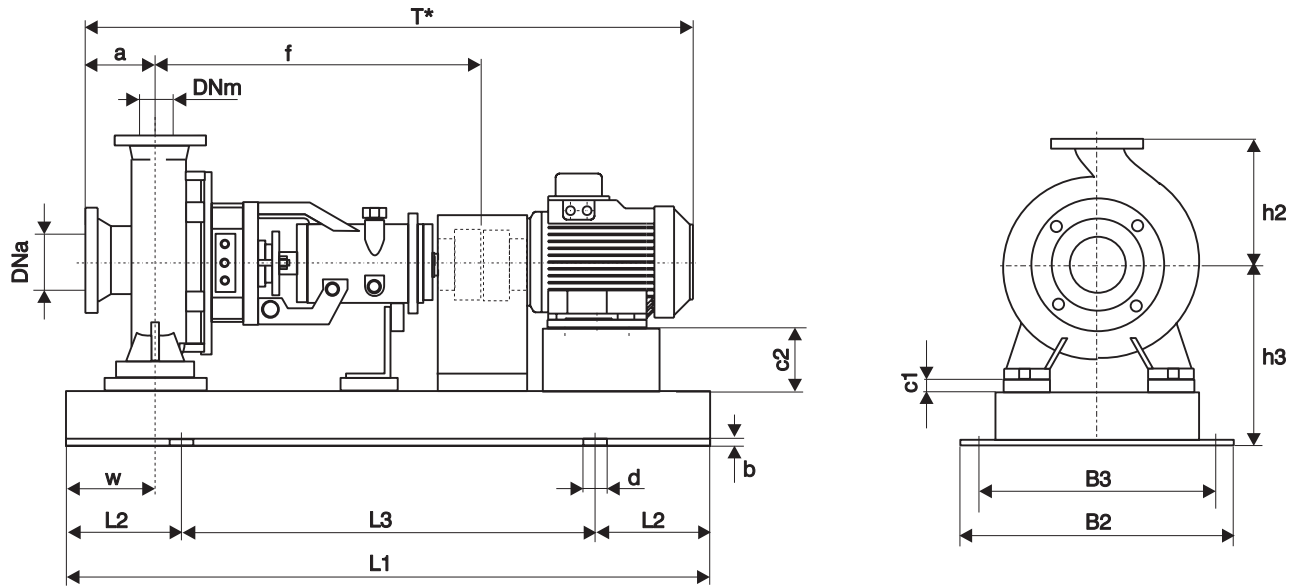

Pompa tipo Pump size	Motore - Motor		Base Base- Plate n.°	DIMENSIONI - DIMENSIONS (mm.)																	Peso * Weight kg
	Grand. Size	KW		DNa	DNm	a	f	h3	h2	L1	L2	L3	B2	B3	w	d	b	c1	c2	T*	
RN 65/125E	112 M2	4	2	80	65	100	360	280	180	1000	170	660	400	360	75	19	30	0	48	825	120
RN 65/125C	132SA2	5.5	2	"	"	"	"	"	"	"	"	"	"	"	75	"	"	0	28	910	135
RN 65/125A	132SB2	7.5	2	"	"	"	"	"	"	"	"	"	"	"	75	"	"	0	28	910	140
RN 65/160E	132 SB2	5.5	2	80	65	100	360	280	200	1000	170	660	400	360	75	19	30	0	28	910	135
RN 65/160D	132 SB2	7.5	2	"	"	"	"	"	"	"	"	"	"	"	75	"	"	0	28	910	140
RN 65/160C	132 MA2	9.2	2	"	"	"	"	"	"	"	"	"	"	"	75	"	"	0	28	910	145
RN 65/160B	160 MA2	11	2	"	"	"	"	"	"	"	"	"	"	"	75	"	"	0	0	1065	170
RN 65/160A	160 MB2	15	2	"	"	"	"	"	"	"	"	"	"	"	75	"	"	0	0	1065	180
RN 65/200C	160MB2	15	2	80	65	100	360	300	225	1000	170	660	400	360	75	19	30	0	20	1065	190
RN 65/200B	160 L2	18.5	2	"	"	"	"	"	"	"	"	"	"	"	75	"	"	0	20	1065	200
RN 65/200A	180 M2	22	3	"	"	"	"	"	"	1200	205	790	440	400	75	"	"	0	0	1145	230
RN 65/250C	180 M2	22	3	80	65	100	470	320	250	1200	205	790	440	400	90	19	30	0	20	1255	265
RN 65/250B	200 LA2	30	4	"	"	"	"	"	"	1500	245	1010	460	420	90	"	"	0	0	1350	335
RN 65/250A	200 LB2	37	4	"	"	"	"	"	"	"	"	"	"	"	90	"	"	0	0	1350	360
RN 80/160	132 SA2	7.5	2	100	80	125	360	300	225	1000	170	660	400	360	75	19	30	0	48	935	150
RN 80/160D	132 MA2	9.2	2	"	"	"	"	"	"	"	"	"	"	"	75	"	"	0	48	935	155
RN 80/160C	160 MA2	11	2	"	"	"	"	"	"	"	"	"	"	"	75	"	"	0	20	1090	180
RN 80/160B	160 MB2	15	2	"	"	"	"	"	"	"	"	"	"	"	75	"	"	0	20	1090	190
RN 80/160A	160 L2	18.5	2	"	"	"	"	"	"	"	"	"	"	"	75	"	"	0	20	1090	200
RN 80/200B	180 M2	22	3	100	80	125	470	300	250	1200	205	790	440	400	75	19	30	0	0	1280	260
RN 80/200A	200 LA2	30	4	"	"	"	"	320	"	1500	245	1010	460	420	75	"	"	20	0	1375	330
RN80/250E	180 M2	22	5	100	80	125	470	320	280	1200	205	790	505	465	90	19	30	0	20	1280	285
RN 80/250D	200 LA2	30	5	"	"	"	"	"	"	"	"	"	"	"	90	"	"	0	0	1375	340
RN 80/250C	200 LB2	37	5	"	"	"	"	"	"	"	"	"	"	"	90	"	"	0	0	1375	365
RN 80/250B	225 M2	45	6	"	"	"	"	365	"	1300	215	870	540	460	90	24	15	50	25	1435	405
RN 80/250A	250 M2	55	6	"	"	"	"	415	"	"	"	"	"	"	90	"	"	75	25	1470	455
RN 100/200E	160 L2	18.5	3	125	100	125	470	320	280	1200	205	790	440	400	90	19	30	0	40	1200	250
RN 100/200D	180 M2	22	3	"	"	"	"	"	"	"	"	"	"	"	90	"	"	0	20	1280	275
RN 100/200C	200 LA2	30	4	"	"	"	"	"	"	1500	245	1010	460	420	90	"	"	0	0	1375	340
RN 100/200B	200 LB2	37	4	"	"	"	"	"	"	"	"	"	"	"	90	"	"	0	0	1375	365
RN 100/200A	225 M2	45	6	"	"	"	"	390	"	1300	215	870	540	460	90	24	15	50	25	1435	395
RN 100/250B	250 M2	55	6	125	100	140	470	415	280	1300	215	870	540	460	90	24	15	50	25	1485	465
RN 100/250A	280 S2	75	7	"	"	"	"	445	"	1450	235	980	560	510	90	"	"	80	25	1485	665

* Variabile a seconda del costruttore del motore