



**SALVATORE
ROBUSCHI
POMPE PARMA**

INGOMBRI CON GIUNTO SPAZIATORE

RD – RG

Data: 09-06-06

N : T-1661

T-1661 pag. 1

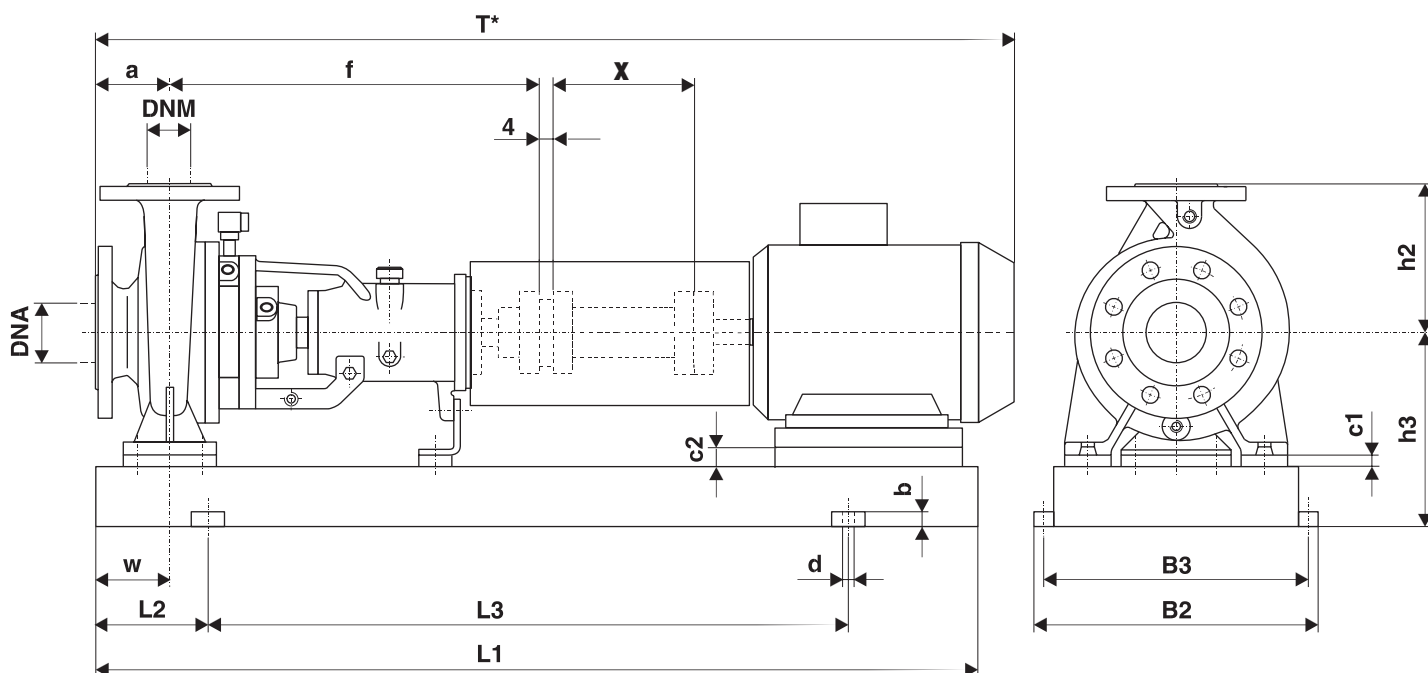

2900 1/min

Pompa Tipo Pump Size	Motore - Motor		Basamento Base - plate No	Dimensioni - Dimension																Peso Weight Kg	
	Size	KW		DNa	DNm	a	f	h3	h2	L1	L2	L3	B2	B3	w	d	b	c1	c2		T
32-12	80	1,1	2	50	32	80	385	232	140	1000	170	660	400	360	60	19	30	-	47	841	62
	90S	1,5	"	"	"	"	"	"	"	"	"	"	"	"	"	"	"	-	37	864	65
	90L	2,2	"	"	"	"	"	"	"	"	"	"	"	"	"	"	"	-	42	889	68
	100L	3	"	"	"	"	"	"	"	"	"	"	"	"	"	"	"	-	27	927	73
32-16	112M	4	"	"	"	"	"	"	"	"	"	"	"	"	"	"	"	-	15	941	82
	90S	1,5	2	50	32	80	385	252	160	1000	170	660	400	360	60	19	30	-	42	864	69
	90L	2,2	"	"	"	"	"	"	"	"	"	"	"	"	"	"	"	-	42	889	72
	100L	3	"	"	"	"	"	"	"	"	"	"	"	"	"	"	"	-	32	927	77
	112M	4	"	"	"	"	"	"	"	"	"	"	"	"	"	"	"	-	20	941	86
32-20	132S	5,5	"	"	"	"	"	"	"	"	"	"	"	"	"	"	"	-	-	1030	128
	132S	7,5	"	"	"	"	"	"	"	"	"	"	"	"	"	"	"	-	-	"	"
	100L	3	2	50	32	80	385	280	180	1000	170	660	400	360	60	19	30	-	60	927	83
	112M	4	"	"	"	"	"	"	"	"	"	"	"	"	"	"	"	-	48	941	92
40-12	132S	5,5	"	"	"	"	"	"	"	"	"	"	"	"	"	"	"	-	28	1030	134
	132S	7,5	"	"	"	"	"	"	"	"	"	"	"	"	"	"	"	-	-	"	"
	160M	11	"	"	"	"	"	"	"	"	"	"	"	"	"	"	"	-	-	1165	168
	80	1,1	2	65	40	80	385	247	140	1000	170	660	400	360	60	19	30	15	47	841	65
	90S	1,5	"	"	"	"	"	"	"	"	"	"	"	"	"	"	"	-	37	864	68
40-16	90L	2,2	"	"	"	"	"	"	"	"	"	"	"	"	"	"	"	-	42	889	71
	100L	3	"	"	"	"	"	"	"	"	"	"	"	"	"	"	"	-	27	927	76
	112M	4	"	"	"	"	"	"	"	"	"	"	"	"	"	"	"	-	15	941	85
	132S	5,5	"	"	"	"	"	252	"	"	"	"	"	"	"	"	"	-	20	1030	127
	132S	7,5	"	"	"	"	"	"	"	"	"	"	"	"	"	"	"	-	-	"	"
40-20	160M	11	"	"	"	"	"	"	"	"	"	"	"	"	"	"	"	-	-	1165	163
	90L	2,2	2	65	40	80	385	252	160	1000	170	660	400	360	60	19	30	-	42	889	73
	100L	3	"	"	"	"	"	"	"	"	"	"	"	"	"	"	"	-	32	927	79
	112M	4	"	"	"	"	"	"	"	"	"	"	"	"	"	"	"	-	20	941	87
	132S	5,5	"	"	"	"	"	"	"	"	"	"	"	"	"	"	"	-	-	1030	129
40-25	160M	11	"	"	"	"	"	"	"	"	"	"	"	"	"	"	"	-	-	"	"
	160M	15	"	"	"	"	"	"	"	"	"	"	"	"	"	"	"	-	-	1165	163
	112M	4	2	65	40	100	385	280	180	1000	170	660	400	360	60	19	30	-	48	961	91
	132S	5,5	"	"	"	"	"	"	"	"	"	"	"	"	"	"	"	-	28	1050	133
	132S	7,5	"	"	"	"	"	"	"	"	"	"	"	"	"	"	"	-	-	"	"
40-25	160M	15	"	"	"	"	"	"	"	"	"	"	"	"	"	"	"	-	-	1185	167
	160L	18,5	"	"	"	"	"	"	"	"	"	"	"	"	"	"	"	-	-	"	"
	180M	22	"	"	"	"	"	"	"	"	"	"	"	"	"	"	"	-	-	1390	239
	200L	30	4	"	"	"	"	320	"	1500	245	1010	460	420	"	"	"	20	-	300	300
	132S	7,5	3	65	40	100	500	300	225	1200	2050	790	440	400	75	19	30	-	48	1165	159
50-12	160M	11	"	"	"	"	"	"	"	"	"	"	"	"	"	"	"	-	20	1300	193
	160M	15	"	"	"	"	"	"	"	"	"	"	"	"	"	"	"	-	-	"	"
	80	1,1	2	80	50	100	385	252	160	1000	170	660	400	400	60	19	30	-	52	861	68
	90S	1,5	"	"	"	"	"	"	"	"	"	"	"	"	"	"	"	-	42	884	71
	90L	2,2	"	"	"	"	"	"	"	"	"	"	"	"	"	"	"	-	42	884	71
50-12	100L	3	"	"	"	"	"	"	"	"	"	"	"	"	"	"	"	-	-	709	74
	100L	3	"	"	"	"	"	"	"	"	"	"	"	"	"	"	"	-	32	947	79
	112M	4	"	"	"	"	"	"	"	"	"	"	"	"	"	"	"	-	20	961	87
	132	5,5-7,5	"	"	"	"	"	"	"	"	"	"	"	"	"	"	"	-	-	1050	127

(*) Quota indicativa può variare in funzione della marca del motore

Not binding dimension that can change according to motor mak

Quote e pesi suscettibili di variazione

Dimensions and weights are subjected to variations

n = 2900 1/min

Pompa Tipo Pump Size	Motore - Motor		Basamento Bed - plate No.	Dimensioni - Dimension																	Peso Weight Kg
	Size	KW		DNa	DNm	a	f	h3	h2	L1	L2	L3	B2	B3	w	d	b	c1	c2	T	
50-16	112M	4	2	80	50	100	385	280	180	1000	170	660	400	360	60	19	30	-	48	961	91
	132S	5,5	"	"	"	"	"	"	"	"	"	"	"	"	"	"	"	-	28	1050	132
	132S	7,5	"	"	"	"	"	"	"	"	"	"	"	"	"	"	"	-	"	1050	132
	160M	11	3	"	"	"	"	"	"	1200	205	790	440	400	"	"	"	-	"	1185	166
	160M	15	"	"	"	"	"	"	"	"	"	"	"	"	"	"	"	-	"	"	175
160L	18,5	"	"	"	"	"	"	"	"	"	"	"	"	"	"	"	-	"	"	"	185
50-20	132S	7,5	3	80	50	100	385	280	200	1200	205	790	440	400	60	19	30	-	28	1050	137
	160M	11	"	"	"	"	"	"	"	"	"	"	"	"	"	"	"	-	"	1185	171
	160M	15	"	"	"	"	"	"	"	"	"	"	"	"	"	"	"	-	"	"	180
	160L	18,5	"	"	"	"	"	"	"	"	"	"	"	"	"	"	"	-	"	"	190
	180M	22	"	"	"	"	"	300	"	"	"	"	"	"	"	"	"	-	20	1275	217
50-25	160M	15	4	80	50	125	500	300	225	1500	245	1010	460	420	75	19	30	-	20	1325	206
	160L	18,5	"	"	"	"	"	"	"	"	"	"	"	"	"	"	"	-	"	"	216
	180M	22	"	"	"	"	"	"	"	"	"	"	"	"	"	"	"	-	"	1415	239
	200L	30	"	"	"	"	"	320	"	"	"	"	"	"	"	"	"	-	20	1450	304
	200L	37	"	"	"	"	"	"	"	"	"	"	"	"	"	"	"	-	"	"	329
	225M	45	6	"	"	"	"	365	"	1300	215	870	510	460	"	24	13	45	-	1529	381
	250M	55	"	"	"	"	"	390	"	"	"	"	"	"	"	"	"	70	-	1559	416
65-16	132S	5,5	3	100	65	100	500	280	200	1340	205	930	440	400	75	19	30	-	28	1165	152
	132S	7,5	"	"	"	"	"	"	"	"	"	"	"	"	"	"	"	-	"	"	152
	160M	11	"	"	"	"	"	"	"	"	"	"	"	"	"	"	"	-	"	1300	194
	160M	15	"	"	"	"	"	"	"	"	"	"	"	"	"	"	"	-	"	"	203
	160L	18,5	"	"	"	"	"	"	"	"	"	"	"	"	"	"	"	-	"	"	213
65-20	160M	15	4	100	65	100	500	300	225	1500	245	1010	460	420	75	19	30	-	20	1340	211
	160L	18,5	"	"	"	"	"	"	"	"	"	"	"	"	"	"	"	-	"	"	211
	180M	22	"	"	"	"	"	"	"	"	"	"	"	"	"	"	"	-	"	1430	238
	200L	30	"	"	"	"	"	320	"	"	"	"	"	"	"	"	"	-	20	1465	302
	200L	37	"	"	"	"	"	"	"	"	"	"	"	"	"	"	"	-	"	"	327
65-25	180M	22	4	100	65	125	500	320	250	1500	245	1010	460	420	90	19	30	-	20	1455	248
	200L	30	"	"	"	"	"	"	"	"	"	"	"	"	"	"	"	-	"	1490	312
	200L	37	"	"	"	"	"	"	"	"	"	"	"	"	"	"	"	-	"	"	337
	225M	45	7	"	"	"	"	390	"	1450	235	980	560	510	"	24	13	50	25	1569	378
	250M	55	"	"	"	"	"	415	"	"	"	"	"	"	"	"	"	75	25	1569	420
	280S	75	"	"	"	"	"	445	"	"	"	"	"	"	"	"	105	25	1729	620	
65-31	200L	37	7	100	65	125	530	390	280	1450	235	980	560	510	90	19	30	25	50	1570	391
	225M	45	"	"	"	"	"	"	"	"	"	"	"	"	"	24	13	25	25	1630	442
	250M	55	"	"	"	"	"	415	"	"	"	"	"	"	"	"	"	50	-	1670	490
	280S	75	8	"	"	"	"	445	"	1590	235	1120	560	510	"	"	"	80	-	1855	660
	280M	90	"	"	"	"	"	"	"	"	"	"	"	"	"	"	"	80	-	"	725
80-16	132S	7,5	3	125	80	125	500	300	225	1200	205	790	440	400	75	19	30	-	48	1230	167
	160M	11	"	"	"	"	"	"	"	"	"	"	"	"	"	"	"	-	20	1365	201
	160M	15	"	"	"	"	"	"	"	"	"	"	"	"	"	"	"	-	"	"	210
	160L	18,5	"	"	"	"	"	"	"	"	"	"	"	"	"	"	"	-	"	"	220
	180M	22	4	"	"	"	"	"	"	1500	245	1010	460	420	"	"	"	-	"	1455	247
200L	30	"	"	"	"	"	320	"	"	"	"	"	"	"	"	"	-	20	1490	297	
80-20	160L	18,5	4	125	80	125	500	320	250	1500	245	1010	460	420	75	19	30	-	20	1365	225
	180M	22	"	"	"	"	"	"	"	"	"	"	"	"	"	"	"	-	"	1455	252
	200L	30	"	"	"	"	"	"	"	"	"	"	"	"	"	"	"	-	20	1490	316
	200L	37	"	"	"	"	"	"	"	"	"	"	"	"	"	"	"	-	"	"	341
	225M	45	7	"	"	"	"	390	"	1450	235	980	560	510	"	24	13	70	25	1569	392
	250M	55	"	"	"	"	"	415	"	"	"	"	"	"	"	"	"	95	25	1599	427
80-25	200L	30	6	125	80	125	500	390	280	1300	215	870	510	460	90	19	30	25	50	1490	320
	200L	37	"	"	"	"	"	"	"	"	"	"	"	"	"	"	"	25	"	"	345
	225M	45	7	"	"	"	"	"	"	1450	235	980	560	510	"	24	13	25	25	1569	402
	250M	55	"	"	"	"	"	"	"	"	"	"	"	"	"	24	13	25	-	1599	437
	280S	75	8	"	"	"	"	420	"	1590	235	1120	560	510	"	"	"	55	-	1729	505
80-31	250M	55	8	125	80	125	530	415	315	1590	235	1120	560	510	90	24	13	25	25	1629	490
	280S	75	"	"	"	"	"	445	"	"	"	"	"	"	"	"	"	55	25	1855	670
	280M	90	"	"	"	"	"	445	"	"	"	"	"	"	"	"	"	55	25	1855	735
	315S	110	-	"	"	"	"	"	"	"	"	"	"	"	"	"	"	"	"	"	"
	315M	132	-	"	"	"	"	"	"	"	"	"	"	"	"	"	"	"	"	"	"
100-20	180M	22	4	125	100	125	500	320	280	1500	245	1010	460	420	90	19	30	-	20	1455	270
	200L	30	"	"	"	"	"	"	"	"	"	"	"	"	"	"	"	-	"	1490	337
	200L	37	"	"	"	"	"	"	"	"	"	"	"	"	"	"	"	-	"	"	362
	225M	45	7	"	"	"	"	390	"	1450	235	980	560	510	90	24	13	50	25	1569	413
	250M	55	"	"	"	"	"	415	"	"	"	"	"	"	"	"	"	75	25	1640	445
	280S	75	8	"	"	"	"	445	"	1590	235	1120	560	510	"	"	"	105	25	1825	625
100-25	225M	45	8	125	100	140	530	390	280	1590	235	1120	560	510	90	24	13	25	25	1640	436
	250M	55	"	"	"	"	"	415	"	"	"	"	"	"	"	"	"	50	25	1685	475
	280S	75	"	"	"	"	"	445	"	"	"	"	"	"	"	"	"	80	25	1870	655
	280M	90	"	"	"	"	"	445	"	"	"	"	"	"	"	"	"	80	25	1870	720
	315S	110	-	"	"	"	"	"	"	"	"	"	"	"	"	"	"	"	"	"	"

(*) Quota indicativa può variare in funzione della marca del motore

Not binding dimension that can change according to motor mak

Quote e pesi suscettibili di variazione

Dimensions and weights are subjected to variations